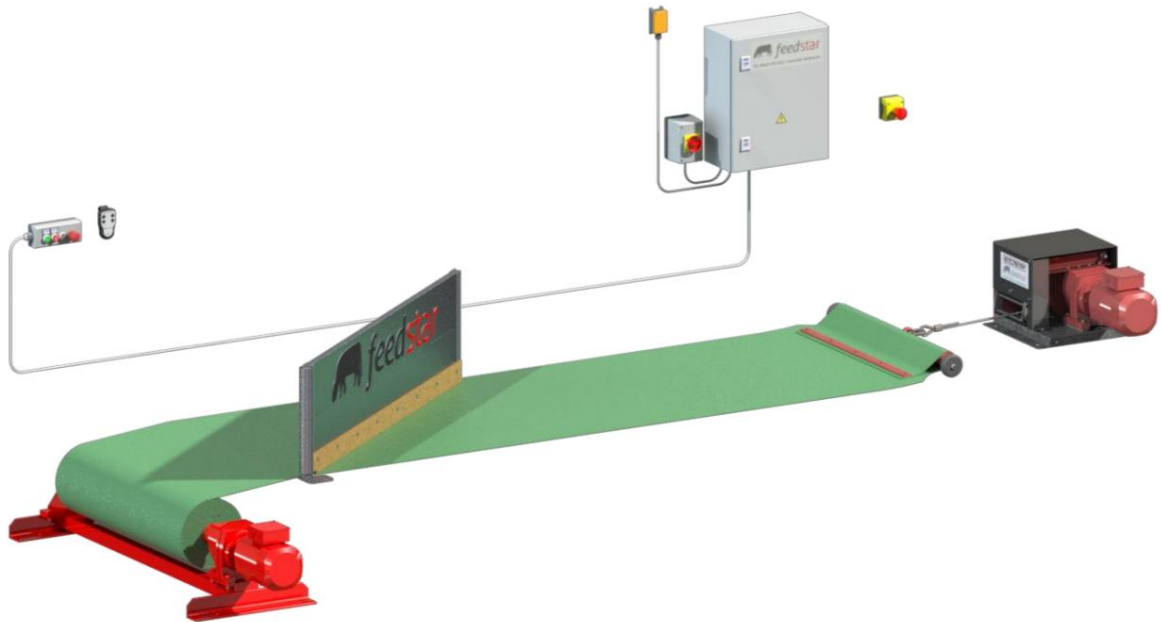




Operating instructions



feedstar Lite11

August 2025

Eder GmbH
Moorweg 5
83104 Tuntenhausen

Tel. +49 8067 181-822
Web www.feedstar.com
Mail feedstar@eder-gmbh.de

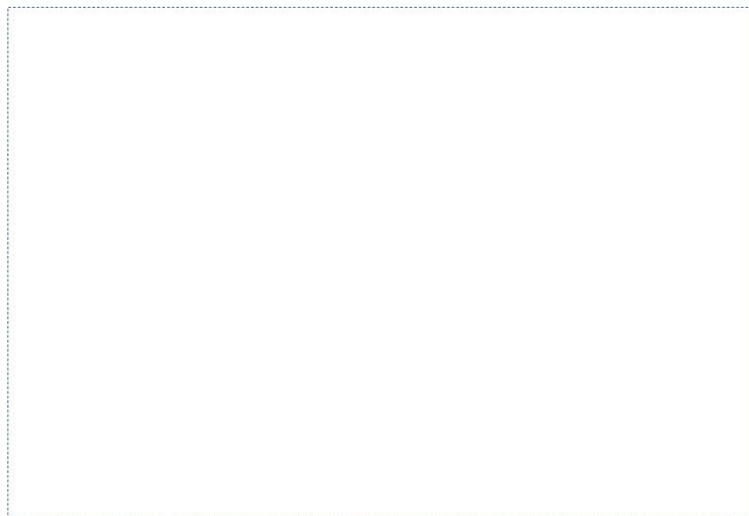
Revision			
Datum	Version	Chapter Basic	Responsible
22.01.2025	V01R03	7.4	Exploded views added
04.08.2025	V01R04	3.6; 4.5.1	

All information and drawings were available on the new website at the time of printing.
ten Stand.

This instruction manual was prepared by us to the best of our knowledge. Should you nevertheless find any errors or ambiguities, please let us know. We are also grateful for any comments and suggestions.

Technical specifications are subject to change without notice.

Type label:



WARNING: RISK OF DESTRUCTION!

Never run the conveyor belt to the winch's end stop without a load.

This operating manual is the property of [Company Name].

Eder GmbH
Moorweg 5
83104 Tuntenhausen

Reproduction, duplication and translation – even in part – of operating instructions from Eder GmbH is only permitted with our prior consent and attribution of the source.

Tuntenhausen, August 4, 2025

Table of contents

1	Notes on documentation.....	7
1.1	Purpose.....	7
1.2	Liability.....	7
1.3	Target group.....	8
1.4	Presentation of information	8
1.5	Structure and organization of safety and warning notices	8
1.6	Storage of documents	9
1.7	Validity of the instructions	9
2	Safety.....	10
2.1	Classification of action-related warnings.....	10
2.2	Machine labels, warning, prohibition and mandatory signs used	11
2.3	General Safety Instructions.....	12
2.4	Warnings	13
2.4.1	Entire Plant	13
2.4.2	Hazards in the area of the plant.....	16
2.4.3	Hazards to humans and animals from feed and additives	17
2.4.4	Hazards during transport	18
2.5	General protective measures.....	19
2.6	Personal Protective Equipment.....	19
2.7	Operator's obligations.....	20
2.8	Staff training.....	20
2.9	Safety devices / Emergency stop button.....	21
3	Functional description	22
3.1	Intended Use	22
3.2	Foreseeable misuse	22
3.3	Retrofitted components	22
3.4	Feedstar Basic Setup	23
3.5	Optional additional components	24
3.5.1	Lateral guide rollers on the drawbar	24
3.5.2	Reversing device with deflection roller.....	24
3.5.3	Lower roll-back device with deflection roller	25
3.5.4	Steel cover with support beam	26
3.5.5	Manual residual feed flap.....	27
3.5.6	Sign drawbar.....	28
3.5.7	End stop for roll-back device.....	28

3.5.8	Safety circuit for the end stop of the roll-back device.....	29
3.5.9	Modular wall system.....	29
3.5.10	Precast concrete parts	30
3.5.11	End board (provided by the customer).....	31
3.6	Control unit	32
3.7	Control box	33
3.8	Type plate.....	33
3.9	Technical Data	33
4	Montage	34
4.1	Winch Installation	34
4.2	Assembly of the roll-back device:.....	36
4.3	Final assembly:	37
4.4	Assembly of optional additional components	39
4.4.1	Reversing device with deflection	39
4.4.2	Manual residual feed flap.....	40
4.4.3	Sign drawbar.....	40
4.4.4	Rubber lip.....	41
4.4.5	Modulwand	42
4.4.6	Limit switch on the retraction device.....	43
4.5	Electrical installation	44
4.5.1	Conductor cross-sections in relation to the components.....	45
4.5.2	Connecting the radio remote control.....	46
5	Operation.....	47
5.1	Filling Feedstar.....	48
5.2	Empty Feedstar	49
6	Disturbances	50
7	Maintenance and inspection.....	51
7.1	General Information.....	51
7.2	Maintenance plan.....	51
7.3	Gear oil.....	52
7.4	Exploded Views	52
7.4.1	Winch Lite11 right	52
7.4.2	Winde Lite11 left.....	53
7.5	Repairs	53
8	Dismantling and decommissioning.....	54
8.1	Decommissioning.....	54

8.2	Final decommissioning.....	54
9	Recycling and disposal	55
10	Declaration of Conformity	56

List of illustrations

Fig. 1	Emergency stop button in the winch area	21
Fig. 2	Emergency stop on the external button.....	21
Fig. 3	Feedstar, schematic overview.....	23
Fig. 4	Lateral guide rollers on the drawbar (optional)	24
Fig. 5	Return roller device with deflection roller (optional).....	24
Fig. 6	Lower roll-back device with deflection roller (optional)	25
Fig. 7	Steel cover with support beam (optional)	26
Fig. 8	Manual residual feed flap (optional).....	27
Fig. 9	Sign Drawbar.....	28
Fig. 10	End stop for roll-back device (optional).....	28
Fig. 11	Safety circuit for roll-back device (optional).....	29
Fig. 12	Modular wall system installed.....	30
Fig. 13	Precast concrete elements	30
Fig. 14	End board for winch (provided by the customer).....	31
Fig. 15	external button.....	32
Fig. 16	Radio remote control (optional)	32
Fig. 17	Switch box and main disconnect switch.....	33
Fig. 18	Type plate.....	33
Fig. 19	Mounting of Lite11 winch – motor on the right.....	34
Fig. 20	Mounting of Lite11 winch – motor on the left.....	34
Fig. 21	Dimensions of the roll-back device.....	36
Fig. 22	Mounting of the roll-back device.....	36
Fig. 23	Belt inlet rewind device.....	36
Fig. 24	Assembly of the roll-back device	37
Fig. 25	Assembly of rope and rope stopper.....	38
Fig. 26	End board.....	38
Fig. 27	Mounting RRV with deflection.....	39
Fig. 28	Assembly of residual feed flap.....	40
Fig. 29	Mounting sign drawbar.....	41
Fig. 30	Mounting rubber lip	41
Fig. 31	Assembly of H-supports and end supports.....	42



Fig. 32 Inserting the module wall.....42

Fig. 33 Limit switch for roll-back device43

Fig. 34 Receiver connection cable with strain relief46

Fig. 35 Receiver plug connection to terminal 2X2.....46

Fig. 36 Filling the Feedstar48

Fig. 37 Emptying the Feedstar.....49



1 Notes on documentation

1.1 Purpose

This operating manual is intended to help you become familiar with the system and to derive full functional benefit from its high performance.

The operating instructions contain important information for the safe, proper, and effective use of the system. The instructions must be followed carefully to avoid hazards, reduce repair costs and downtime, and increase the reliability and service life of the system.

Persons responsible for the assembly, commissioning, operation, or maintenance of the system must have read, understood, and followed the operating instructions. For this reason, these instructions must be kept at the system's location at all times.

The local safety and accident prevention regulations and the chapter "Safety" (see Chapter 2) must be strictly observed.

1.2 Liability

Eder GmbH accepts no liability for damages and malfunctions resulting from failure to observe the operating instructions.

Unauthorized modifications and alterations to the system are prohibited for safety reasons. If modifications and alterations to the system are not expressly authorized by Eder GmbH, the operating permit becomes invalid and no liability will be assumed for any resulting damages.

Examples of such changes include:

- Removal of protective devices
- Changing the band length/width
- Changing the belt speeds

Eder GmbH assumes no liability for damages resulting from such interventions.

No liability accepted. The operating license is revoked. The user bears all risk!

We reserve the right to make technical changes that serve the further development and improvement of the system as well as technological progress.

1.3 Target group

This operating manual is aimed at the following target groups:

- trained operating personnel
- trained maintenance personnel

1.4 Presentation of Information

To enable you to work quickly and safely with these instructions, uniform formatting, numbering, symbols, safety instructions (see chapter 2.1), terms and abbreviations are used.

Instructions are indicated by an arrow .

- You can recognize lists by a preceding period.

A NOTICE

Here you will find tips on how to avoid potential property damage.

INFORMATION Here you will find helpful information about the product in general or how to use it.

1.5 Structure and organization of the safety and warning notices

The safety instructions in this operating manual follow a uniform format. They describe residual risks that could cause personal injury or property damage.

General structure



SIGNAL WORD

Type and source of the danger.

(Warning sign)

Consequences of non-compliance

• Measures for hazard prevention

The following applies:

Warning sign: draws attention to the danger

Signal word: indicates the severity of the danger

The safety instructions are followed by action guidelines. These action guidelines must be followed to avert danger.



1.6 Storage of documents

These operating instructions and all accompanying documents must be kept readily available to all persons working on the system at all times. The location of the documents must be clearly identifiable to these persons.

1.7 Validity of the instructions

This operating manual is exclusively for the feedstar Basic Lite11 from Eder GmbH valid.

2 Security

When using, troubleshooting and maintaining the machine, observe the warnings preceding each action, as well as all safety signs affixed to the machine.

2.1 Classification of action-related warnings



Indicates an immediately dangerous situation which, if ignored, will result in death or serious injury.

Consequences of non-compliance

• Measures for hazard prevention



Indicates a potentially dangerous situation which, if not heeded, could result in serious injury or death. which can lead to death or serious injury.

Consequences of non-compliance

• Measures for hazard prevention



Indicates a potentially hazardous situation which, if ignored, could result in minor or slight injury.

Consequences of non-compliance

• Measures for hazard prevention

2.2 Machine labels, warning, prohibition and mandatory signs used

The warning and safety signs affixed to the equipment must be observed. They must not be altered or removed. Damaged signs must be replaced immediately. The following list serves to explain symbols in these instructions or on the machine.

Information and warning signs



Warning about
Danger point



Warning of dangerous electrical
voltage



Warning about
Risk of intrusion



Warning about
Hand injuries



Warning about
automatic start-up



Warning about
hot surfaces



Warning of falling danger

Mandatory signs



Unlock before work!



Use eye protection!



Follow the instructions!



Wear protective gloves!



Use foot protection!



2.3 General Safety Instructions

A fundamental prerequisite for the safe handling and trouble-free operation of this system is knowledge of the basic safety instructions and the operating instructions.

Occupational safety regulations.

This operating manual contains all the important information to ensure the safe operation of the system. to operate legally.

The facility must be protected against access by unauthorized persons.

The company's internal occupational safety regulations must be observed.

A NOTICE

Operating the system without safety devices is negligent and does not fall under the category of "foreseeable misuse"!

Therefore, this operating manual does not explicitly warn of dangers that may arise from operation without safety devices.

Residual risks

Residual hazards are hazards that, despite a safe design and technical protective devices, represent an unavoidable, non-obvious risk arising from the use of the product.

A NOTICE

To avert any remaining risks, all safety instructions in this operating manual must be followed.

All work must be carried out in accordance with the legal and professional association regulations on occupational safety and accident prevention.

Work on the system may only be carried out by trained and instructed specialist personnel.

Unauthorized changes

Unauthorized modifications to the Feedstar can pose a danger. No alterations, additions, or modifications that could compromise safety are permitted.

2.4 Warnings

2.4.1 Entire system

WARNING: Danger from tampering with protective measures and equipment

Do not make any changes to the system.

• Modifications to the machine must be approved in writing by the manufacturer.

Do not tamper with protective devices.

Only operate the machine if all safety devices are properly engaged.
needed and are in operation.

WARNING Electrical hazard from indirect contact with parts that have become live due to faulty conditions



• Work on electrical equipment may only be carried out by authorized specialists.
be performed sonically.

Maintenance and modification work on the machine should only be carried out when it
is disconnected from the power supply.

• Switch off the machine at the main switch and secure it against being switched on again.

• Put up a sign saying "Do not switch on machine".

• Clean electrical equipment regularly and check for damage.

Cables must not be pinched or squeezed.

Cables must be laid in such a way that they do not create tripping hazards or can
be damaged.

• Secure loose connections.

Replace damaged cables immediately .

WARNING Hazards due to movement of plant components

If the system is switched on during the repair or if the repair is carried out on the
running system, this can lead to serious or fatal injuries.

When working on the system , it is necessary that the system be completely shut down.
switches and is secured against being switched on again, for example with a lock.

• Before switching on, ensure that no persons are in the danger zone.
stay rich.

Wear the prescribed personal protective equipment

- Safety shoes
- Protective gloves
- Safety helmet for overhead work

⚠ WARNING: Danger due to automatic start-up



Only operate the system with functioning safety devices.

Protective devices must not be removed or tampered with.

⚠ WARNING Danger due to lack of possibility to shut down the system as quickly as possible in an emergency switch

The location and function of the emergency stop devices, as well as the procedure in case of an emergency, must be known to all persons working on the plant.

Emergency stop devices must always be accessible.

Emergency stop devices must under no circumstances be obstructed, covered, or used as hooks.

After repair work, it must be ensured that all emergency stop devices are functioning correctly. tungen are functional.

⚠ WARNING Risk of injury due to structural failure of plant components caused by corrosion

Mechanical hazards due to incorrectly dimensioned or defective machine parts / static strength

Hazard due to component breakage

Please refer to the instructions for the intended use of the automatic feeding system.

Regularly check the mechanical and electrical components for

Damage; replace damaged parts if necessary.

Ensure that all safety and hazard warnings are complete and legible . notes.

Adhere to the maintenance intervals.

Replace damaged or missing corrosion protection.

Wear the prescribed personal protective equipment

- Safety shoes
- Protective gloves
- Safety helmet for overhead work

⚠ WARNING Hazards due to faulty assembly and incorrect or unauthorized use set parts

• When replacing components, use only original spare parts or Manufacturer-approved replacement parts.

The work may only be carried out by trained specialists .

⚠ CAUTION: Risk of injury from contact with hot surfaces (motor, bearings, drives)



- ÿ Allow motors, bearings and drives to cool down before working on the machine.
- Wear heat-resistant protective gloves .

⚠ CAUTION: Hazards due to unsuitable design, placement, or marking of controls and displays

Keep displays and controls clean and legible.

Replace incorrect labels immediately .

ÿ Label the control elements and provide warning notices in the operator's language.

ÿ If necessary, label additionally in other user languages.

⚠ CAUTION Danger from direct contact with, arc flash, sparks, fire or Short circuit of live parts caused by the electrical equipment of the plant



ÿ Work on electrical equipment may only be carried out by authorized specialists. be performed sonically.

ÿ Work on the system may only be carried out when it is de-energized and in compliance with safety regulations.

Maintenance and modification work on the machine should only be carried out when it is disconnected from the power supply.

ÿ Switch off the machine at the main switch and secure it against being switched on again

ÿ Put up a sign saying "Do not switch on machine".

ÿ Clean electrical equipment regularly and check for damage.

Cables must not be pinched or squeezed.

Cables must be laid in such a way that they do not create tripping hazards or can be damaged.

ÿ Secure loose connections.

Replace damaged components immediately .

Do not operate the machine if it is damaged.

⚠ CAUTION: Health hazards may occur due to exposure to harsh environmental conditions at plant components located outside of buildings.

Wear clothing appropriate to the environmental conditions .

⚠ CAUTION: Hazards due to noise in the area of the drives

- ÿ Conduct noise measurements.
- ÿ Wear suitable soundproofing if the noise level exceeds 80 dBA.

2.4.2 Hazards in the area of the plant

⚠ WARNING Danger of component breakage if the winch or the rewind device does not switch off

Operate the system **only** with functioning safety devices.

The function of the shutdown device must be checked before commissioning .
will be checked.

⚠ WARNING Danger of cutting, rubbing or abrasions

Danger from rubbing or abrasion on the winch rope

- ÿ Check the rope regularly for damage and replace if necessary.

⚠ WARNING Danger of limb crushing, entanglement or trapping, being caught in the area of the roll-back device



- ÿ Work should only be carried out manually and repairs only when the system is disconnected from the power supply.

Operate the system **only** with functioning safety devices.

Use suitable lifting equipment to open the manhole cover .

- ÿ Before switching on, ensure that no persons are in the danger zone.

⚠ WARNING Danger of limb crushing in the area of the winch and optional belt cleaning



Danger of being pulled in, caught, or caught in the area of the winch.

- ÿ Work on the system may only be carried out by trained and instructed specialist personnel.

Operate the system **only** with functioning safety devices.

- ÿ Perform work only in manual mode of the system.

When working on the system , it is particularly important that the system is completely switched off and secured against being switched back on, e.g. with a lock.

- ÿ Before switching on, ensure that no persons are in the danger zone.

2.4.3 Hazards to humans and animals from feed and additives

WARNING Health hazard from contact with lubricants and cleaning agents

Avoid skin contact with lubricants and cleaning agents as much as possible .

• Skin areas affected after contact with lubricants and cleaning agents should be treated as follows:
Continue cleaning and changing soiled clothes.

Do not allow lubricants and cleaning agents to enter the environment.

• Immediately absorb any spilled substances with a suitable binding agent and dispose of them properly.
gen.

Dispose of lubricants and cleaning agents in an environmentally friendly manner.

WARNING: Risk of environmental damage from substances and materials used

Dispose of the substances and materials used (fats, oils, cleaning agents or solvents) in accordance with legal regulations.

WARNING Risk of injury from slipping, tripping and falling in adverse weather conditions. due to slippery surfaces or during cleaning and maintenance work, e.g., from feed residues

• Keep all traffic routes inside and outside the feeding facility clear of ice and snow at all times.

Remove leftover food immediately .

Keep the floor in the work area clean and dry at all times.

• Connection cables must be laid in such a way that they do not create tripping hazards or can be damaged.

WARNING: Hazard from handling feed components

• When handling different types of animal feed, appropriate personal protective equipment is essential.
Pay attention to protective equipment.

The type of personal protective equipment depends on the equipment being handled.
Animal feed.

⚠ WARNING: Risk of fire due to dried-out feed components

Remove leftover food at regular intervals.

Keep suitable fire extinguishers readily available at the facility.

No smoking or open flames at the facility.

⚠ CAUTION: Risk of illness from mold in feed

Danger from contamination with toxic plant remains

Clean the tape at regular intervals.

Dispose of leftover food properly.

Avoid stirring up dust .

**⚠ CAUTION: Risk of injury to animals due to damaged strap
Risk of injury to animals due to damaged winch rope**

ÿ Check the winch cable for damage at regular intervals.

Repair or replace damaged tape .

⚠ CAUTION: Danger from silage runoff

Dispose of silage wastewater properly.

2.4.4 Hazards during transport

**⚠ CAUTION: Risk of injury during transport, assembly and disassembly due to falling objects.
len of plant components**

Only qualified, trained and instructed personnel may transport the goods.
undertake.

ÿ Designate a qualified spotter for lifting operations/loading procedures

passageways

Use suitable transport vehicles with sufficient load-bearing capacity .

Use suitable and adequately sized lifting equipment .

ÿ Observe the regulations for load securing.

ÿ Note the weight specifications of the system components.

No persons may be under suspended loads.

Pay attention to the center of gravity and the dead weight of the system components.
ten.

Secure loose components against falling or tipping over.

Ensure even load distribution .

Wear the prescribed personal protective equipment

- Safety shoes
- Protective gloves
- Safety helmet for overhead work

2.5 General protective measures

When working on the Feedstar, care must be taken to ensure that no one is endangered. This is especially important if several people are near the system.

Safety devices, protective equipment, and safeguards must be used and maintained appropriately. Their misuse, unauthorized removal, and damage are prohibited.

Children must be kept away from the facility at all times. Eder GmbH cannot be held liable for any damages resulting from non-compliance.

The measures taken against unauthorized start-up and unauthorized commissioning of the plant must not be circumvented.

Repairs during operation, as well as cleaning and polishing of running parts, are prohibited.

The following accident prevention regulations essentially apply to the Feedstar:

It was respected.

General regulations DGUV V1 (formerly BGV A1 or VBG 1)

Electrical machines DGUV V3 (formerly BGV A3 or VBG 4)

2.6 Personal Protective Equipment

Personal protective equipment must be used during operation, maintenance, setup or troubleshooting; this includes, among other things...

- Eye protection
- Hand protection
- Foot protection



2.7 Operator's Obligations

The operator of the plant must ensure that

- The commissioning and operation of the machine is carried out exclusively by trained personnel.
- Cleaning is carried out by trained specialists.
- These operating instructions are always available. They are part of the product.
- The operating instructions and, in particular, the safety instructions have been read and understood by the authorized personnel before operation, maintenance and repair.
- The permissible operating conditions must be observed.
- In case of replacement, only original parts, manufacturer-approved parts or parts They must be used with the appropriate specifications. Other spare parts may only be installed after consultation with the manufacturer.
- The machine may only be operated in perfect, safe working order. Its technical condition must comply at all times with country-specific legal requirements and regulations.
- The system is used only as intended.
- All safety regulations must be observed.
- All maintenance tasks will be carried out on time and professionally.
- All maintenance tasks are performed exclusively by trained personnel. become.
- All maintenance work must be carried out exclusively by qualified personnel.

2.8 Staff training

Before commissioning, staff must receive comprehensive training on:

- the operation of the system
- the execution of professional maintenance

The operator must ensure that the instruction is repeated at appropriate intervals.

2.9 Protective devices / Emergency stop buttons

Protective devices are designed to protect you from injuries in hazardous areas.
it was.

Only operate the system with intact and functioning safety devices. Check that all safety devices are installed before switching on the system.

The Feedstar has two emergency stop buttons located at the following points:

- On the control unit
- In the area of the winch (assembly by the customer)

The emergency stop button interrupts the power supply in an emergency and keeps the system running.
an.

Keep emergency stop buttons unobstructed at all times. Do not tamper with them.

Do not use them for purposes other than their intended use, e.g. as clothes hooks.



Fig. 1 Emergency stop button in the winch area



Fig. 2 Emergency stop on the external button



3 Functional description

3.1 Intended Use

The Feedstar is exclusively for the horizontal transport of green fodder or mixed ration on smooth floors.

Proper use also includes compliance with the operating, maintenance and repair conditions prescribed by the manufacturer.

The system may only be used, maintained, and repaired by persons who are familiar with it and informed about the associated dangers.

3.2 Foreseeable Misuse

Any use other than that described above may lead to hazards and damage and is not in accordance with the intended purpose. This includes, in particular:

- its use as a lifting device
- the system overload
- Operation, maintenance and repair by untrained persons
- improper use with unsuitable parameters and operation in unsuitable environmental conditions (see Chapter 3.9 Technical Data)
- the transport of people and animals
- the use of the plant in a damaged condition
- Failure to follow the operating instructions
- failure to comply with the relevant accident prevention regulations
- the use of unauthorized operating equipment and materials
- inadequate or improper maintenance and upkeep
- Making unauthorized changes
- the use of unsuitable replacement and wear parts
- operation without safety devices
- the manipulation of protective devices

The manufacturer is not liable for any resulting damages; the risk for this is borne by the manufacturer. The user alone.

3.3 Subsequently installed components

The operating license becomes invalid for any components installed subsequently, unless supplied and/or installed by Eder GmbH.

For components and modifications supplied by Eder GmbH, the operator must carry out a corresponding risk assessment.

Unauthorized modifications to the machine exclude the manufacturer's liability for any resulting damage.

3.4 Setup of the Feedstar Basic

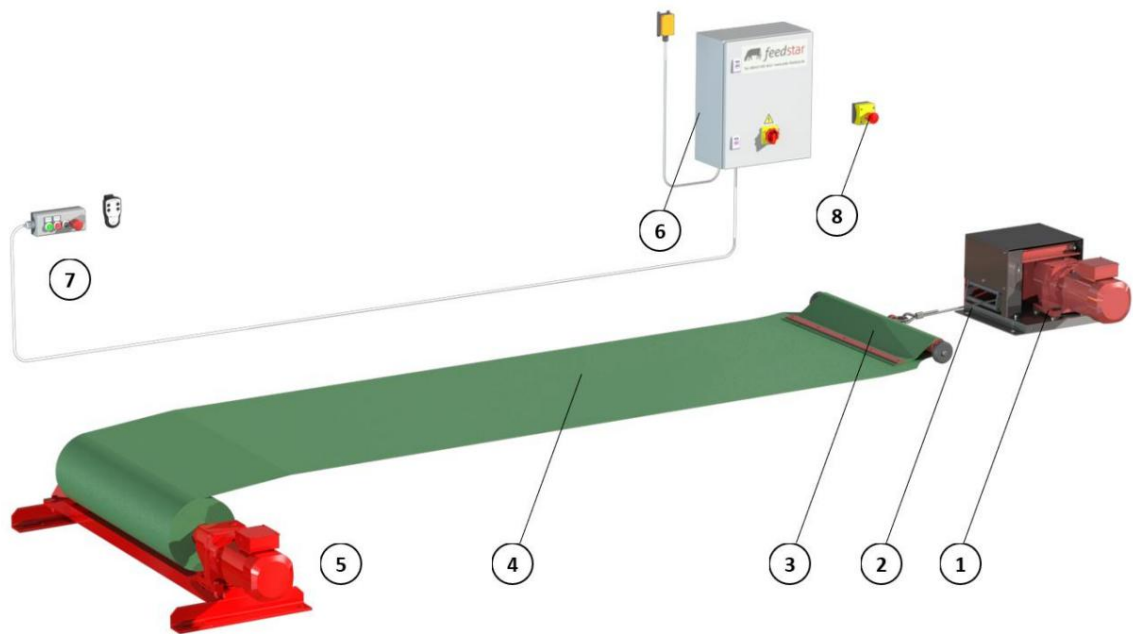


Fig. 3 Feedstar, schematic overview

Item Description		Item Description	
1	winch with motor	2	ropes
3	Zugbalken	4	Pull-in tape
5	Reversing device	6	Control cabinet
7	Main switch	8	External push button with emergency stop
9	Not-Au		

3.5 Optional Additional Components

3.5.1 Lateral guide rollers on the drawbar

Additional guide rollers on the drawbar for extra-long or wide systems. These hold the drawbar in the U-shaped housing in the winch area. The rollers must not be adjusted too tightly.

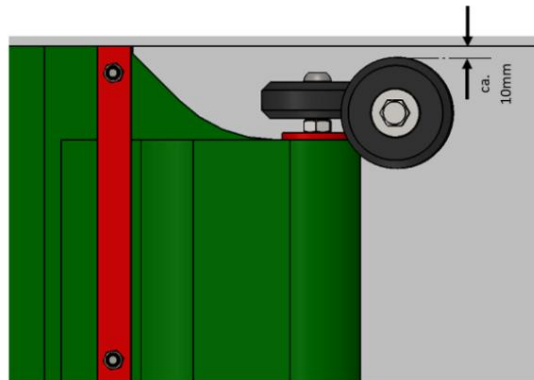


Fig. 4 Lateral guide rollers on the drawbar (optional)

3.5.2 Reversing device with deflection roller

The return mechanism can optionally be equipped with a deflection pulley. This allows the feed to be ejected behind the return roller mechanism.

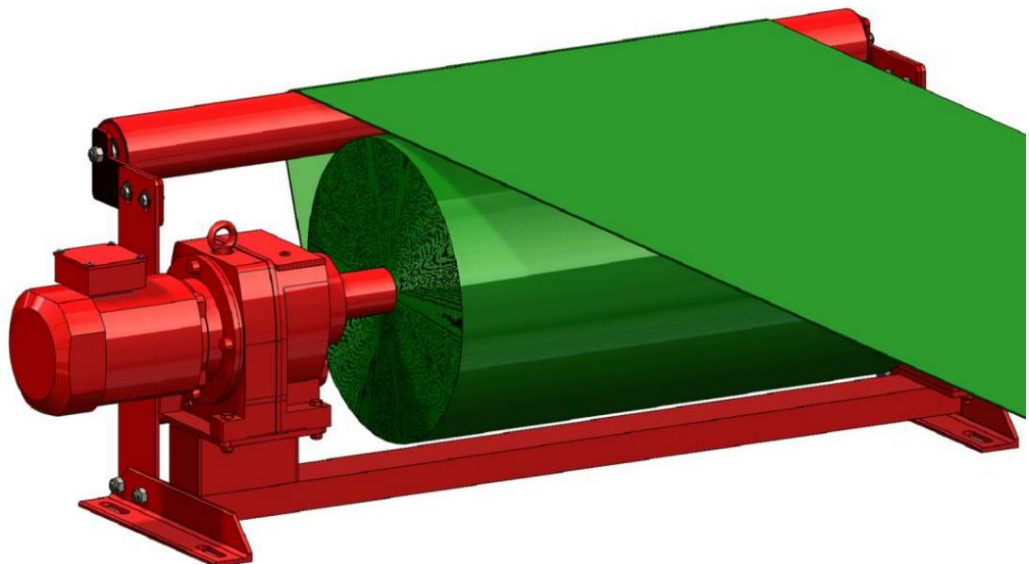


Fig. 5 Retractable roller device with deflection roller (optional)

3.5.3 Lower roll-back device with deflection roller

The reverse roller mechanism is made lower than the standard version by splitting the lower crossbeam. Therefore, the reverse roller mechanism is approximately 50-120mm lower than a standard reverse roller mechanism.

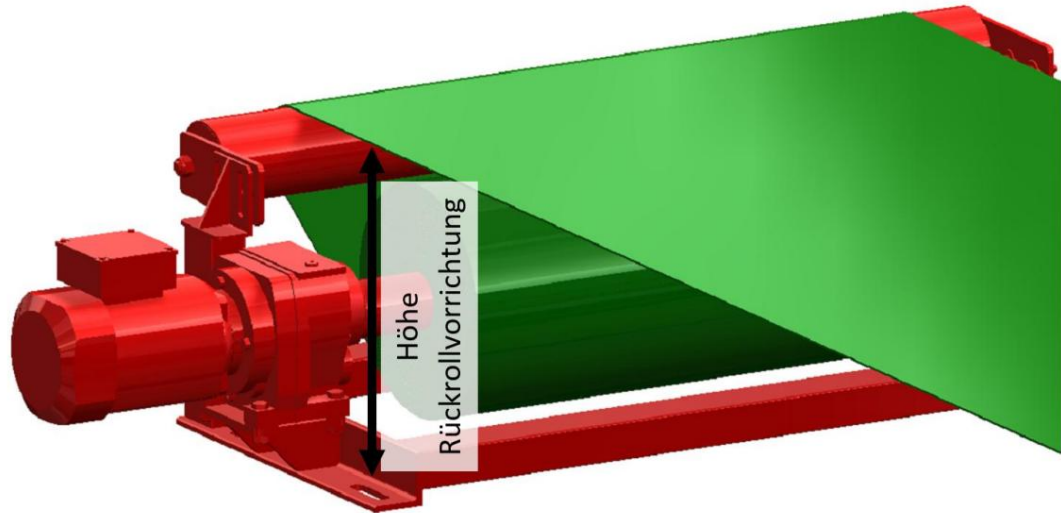


Fig. 6 Lower roll-back device with deflection roller (optional)

3.5.4 Steel cover with support beam

Steel cover for covering the shaft of the roll-back device.

Maximum load approx. 5 tons. Size variable. Dimensions see installation diagram.

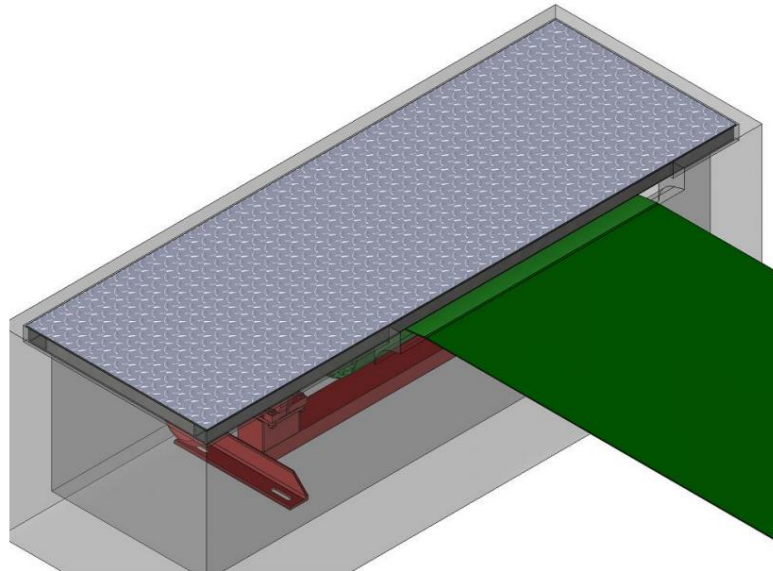


Fig. 7 Steel cover with support beam (optional)

3.5.5 Manual residual feed flap

The residual feed flap allows the residual feed to be pushed out to the side.

Suggestions for clear flap opening in bandwidths:

Minimum bandwidth	(approx. 45°)	optimal 1	optimal 2	Maximum dimension (approx. 30°)
0.70m	1.03m	1.20m		1.44m
0.80m	1.17m	1.50m		1.64m
0.90m	1.31m	1.50m		1.84m
1.00m	1.45m	1.50m	2.00m	2.04m
1.20m	1.74m	2.00m		2.44m
1.40m	2.02m	2.00m	2.60m	2.84m
1.60m	2.30m	2.60m		3.24m
1.80m	2.59m	2.60m	3.30m	3.64m
2.00m	2.87m	3.30m		4.04m

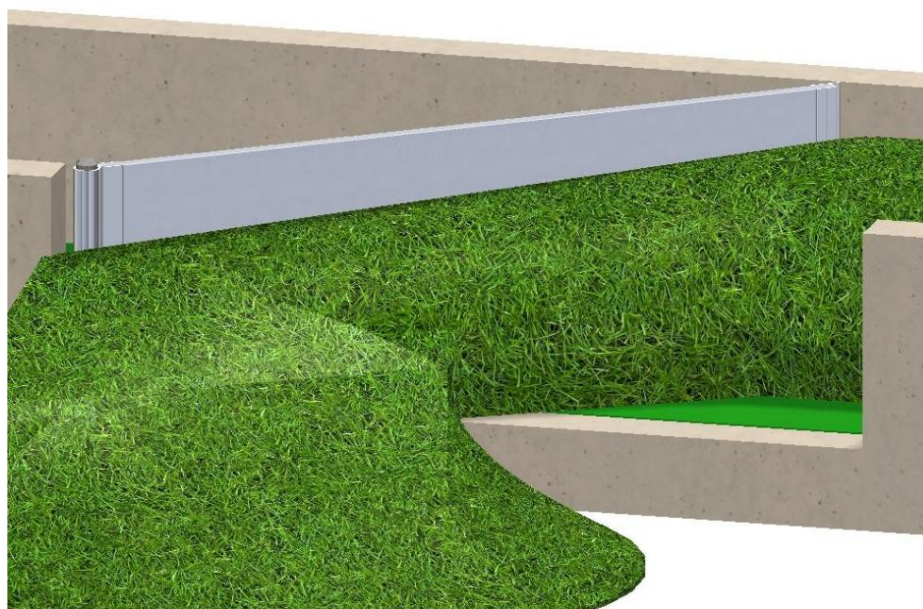


Fig. 8 Manual feed flap (optional)

3.5.6 Sign drawbar

The shield protects the drawbar from feed being pushed forward. Not possible in conjunction with the installation of the end board.

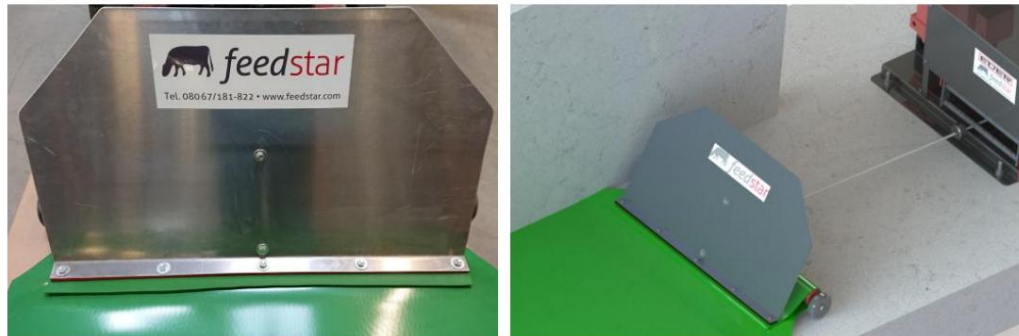


Fig. 9 Sign Drawbar

3.5.7 End stop for roll-back device

The roll-back device can optionally be equipped with an end-of-travel cut-off. This automatically stops the system as soon as the belt is pulled out.

This end stop requires an additional automatic system and is not for standard control.

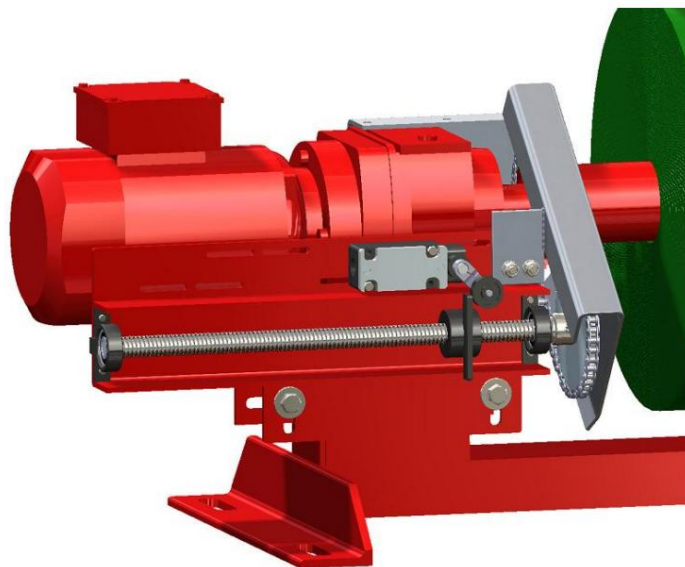


Fig. 10 End stop for roll-back device (optional)

3.5.8 Safety circuit for the end stop of the roll-back device

In addition to the limit switch, the retraction device can be equipped with a safety cut-off. This stops the retraction device if the belt is pulled to the side or folded over during retraction. The safety cut-off is only implemented in conjunction with the limit switch and is intended for wide or long systems.

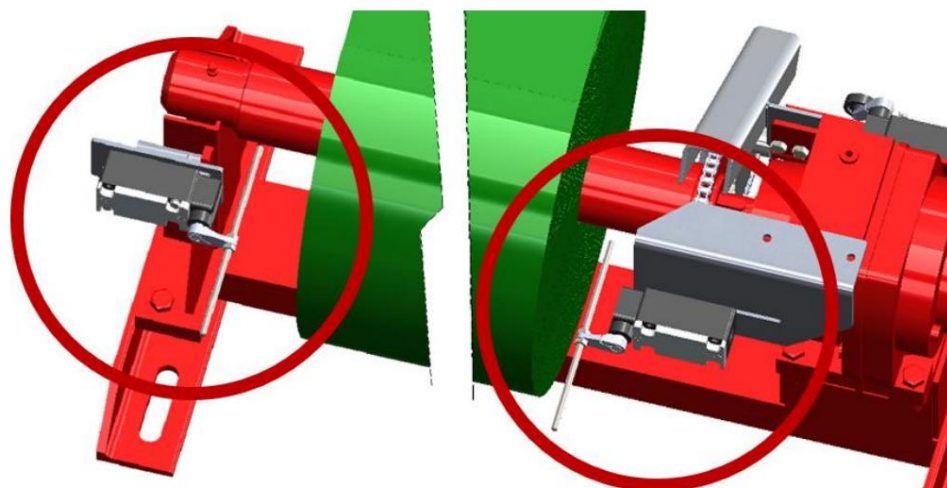
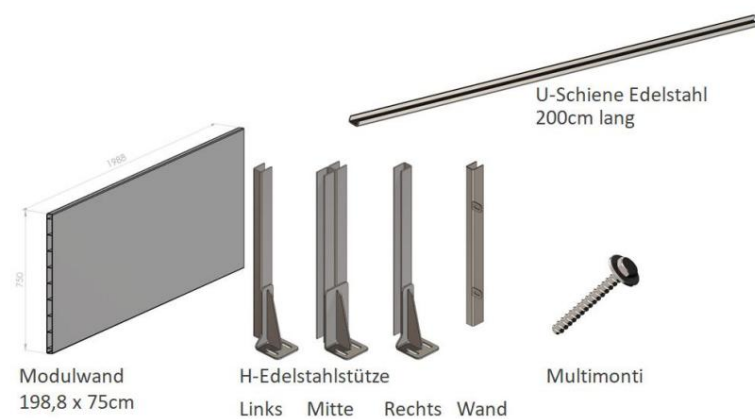


Fig. 11 Safety circuit for roll-back device (optional)

3.5.9 Modular wall system

The modular wall system can optionally be used for the second raised bar wall in single-sided feeding systems. It consists of modular walls measuring 198.8 x 75 cm, H-Edelsteel supports and U-channels.



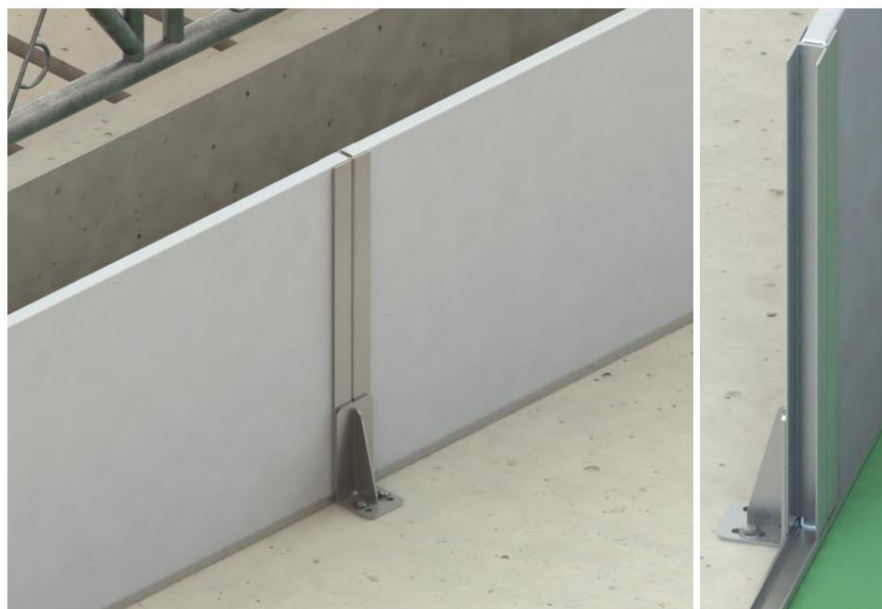


Fig. 12 Modular wall system installed

3.5.10 Precast concrete parts

The following precast concrete elements are available:

Concrete shaft; concrete cover; filling funnel; residual feed discharge; residual feed collection; U-shaped tray.

The dimensions of the precast concrete elements are manufactured individually and in consultation with the client.

Adjustments to the existing terrain and slopes must be made on-site by the client.

The supplied precast concrete elements must be installed according to the specifications of the German Association of Concrete Workers and the currently applicable accident prevention regulations. Maximum permissible dimensional deviations according to Table 1 of DIN 18202.

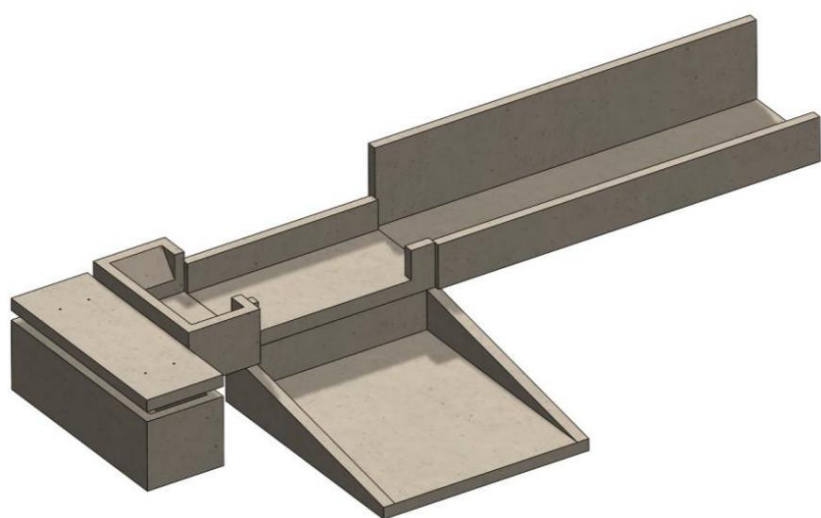


Fig. 13 Precast concrete elements

3.5.11 End board (provided by the customer)

The end plate protects the area from the winch and the rope feed with the limit switch from the lining. Not compatible with the mounting plate for the drawbar.

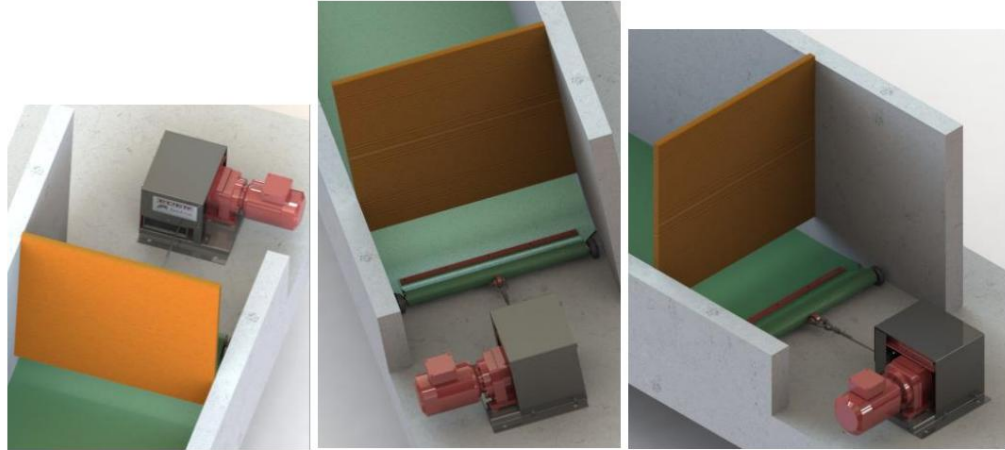


Fig. 14 End board for winch (provided by the customer)

3.6 Control unit

The system is controlled via a mobile control unit using operating elements.

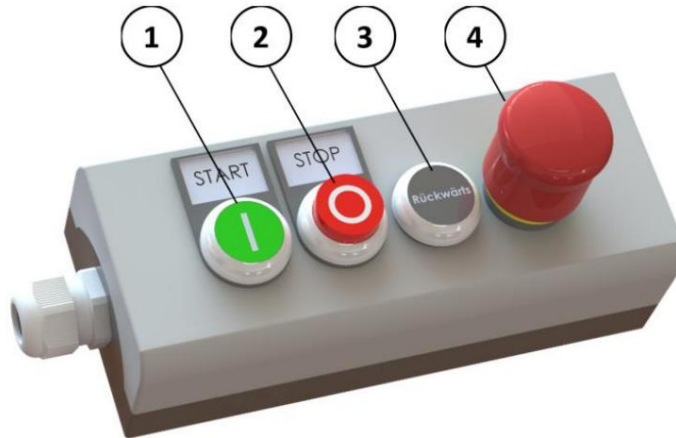


Fig. 15 external button



Fig. 16 Radio remote control (optional)

Item	Description and Function
	Pressing the button once activates the conveyor belt. The belt runs into the barn (forward).
	Pressing the button twice switches the belt off.
3.	Pressing the button (keep it pressed!) makes the belt run out of the barn (backwards)
4	emergency stop buttons
5.	Pressing the wireless button increases the belt speed (only with frequency converter)
6.	Pressing the wireless button reduces the belt speed (only with frequency converter)

3.7 Control box

The main disconnect switch is located at the control box.
(Size approx. b=400 h=500 t=210mm)



Fig. 17 Switch box and main disconnect switch

3.8 Type plate

Attached to the winch:



Fig. 18 Type plate

3.9 Technical Data

Winch type	Lite11
Maximum material load [to]	1
Usable ropes: (plastic), Diameter [mm]	8
Belt speed [m/min]	7
Engine power [kW]	1

All figures are guidelines and must be determined individually.

4 Montage

When assembling the system, the safety instructions mentioned in Chapter 2.3 and the warnings mentioned in Chapter 2.4 must be strictly observed – this will prevent life-threatening injuries, machine damage and other property damage.

4.1 Winch assembly

The winch is mounted horizontally at the end of the conveyor belt, at the level of the feeding table. The winch is secured with four M16x148 anchor bolts.

There are 2 types of LITE11 winches:

Winch motor on the right (standard)

Winch – Motor left.

The center of the feed table is marked on the winch. This is the only way to ensure optimal feeding. Bands guaranteed.

• The length of the pull rope must be chosen so that at least 3 layers of rope remain on the drum winch when the belt is completely wound up.

The rope must be wound up neatly in sequence in every position, as pre-assembled.

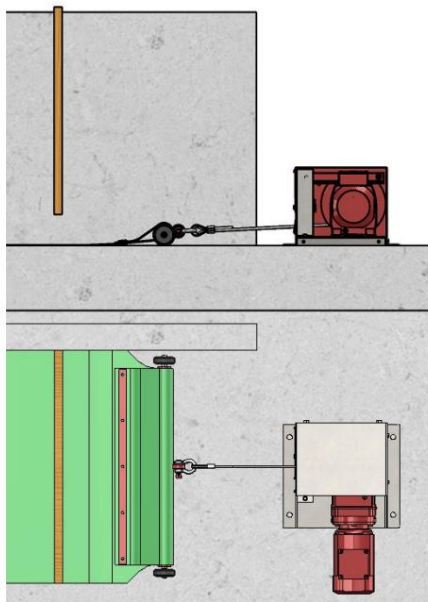


Fig. 19 Assembly of Lite11 winch – motor on the right

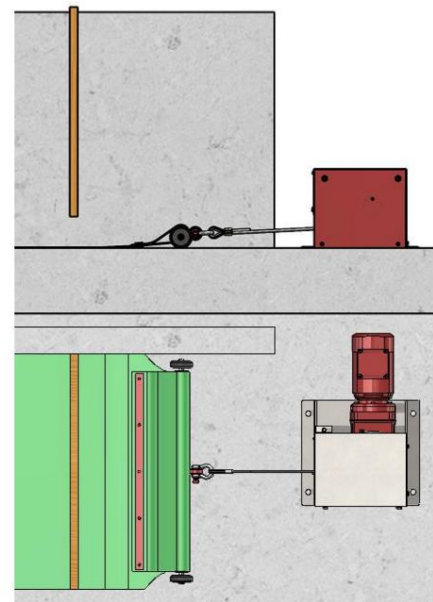


Fig. 20 Assembly of Lite11 winch – motor on the left

 **WARNING: Risk of entrapment in the winch area**



The included protective cover must be installed.

The system must not be operated without a protective cover .

4.2 Assembly of the roll-back device:

The retraction device is mounted horizontally and at an angle to the belt .

The roll-back device is included as standard
 Mounted flush with the ground. The dimensions
 The dimensions of the recess depend on the width
 and length of the feed belt. Please refer to
 the enclosed installation diagram for project-
 specific dimensions.
 The shaft depth can vary depending on the slope.

The roll-back device is secured with 4 bolts .

Zener anchors M16x148 and large washers M16
 are fastened in the shaft.

Remove the roll-off protection (cable tie) on the
 motor.

Shaft height at incline:

The shaft depth on a slope must be corrected
 according to the sketch.

Center of shaft, slope = height RRV +
 50 mm

Pull the band approximately 3-4m into the U-shaped shell .

and adjust the return roller mechanism to exactly
 90° to the feed table.

The sagging transition (on one side the tape is taut,
 on the other it sags) indicates whether it has been
 aligned correctly.

The correct angle of installation can be readjusted
 using the elongated holes on the return roller
 device.

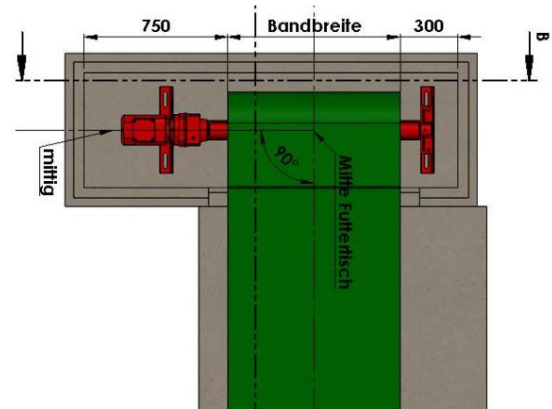


Fig. 21 Dimensions of the roll-back device

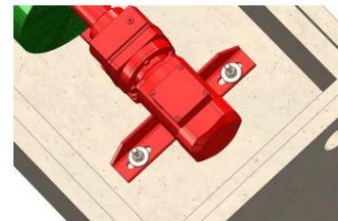


Abb. 22 Mounting of the roll-back device

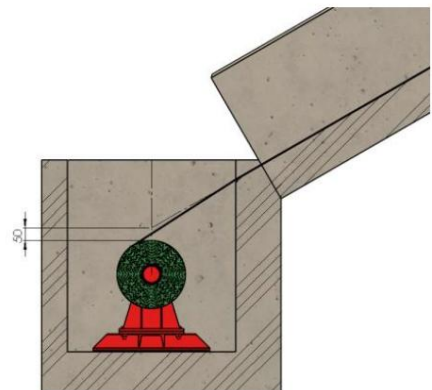
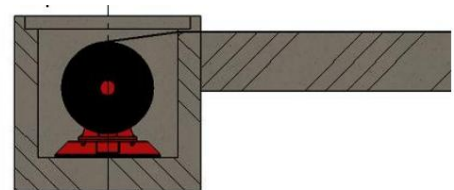


Fig. 23 Belt inlet rewind device

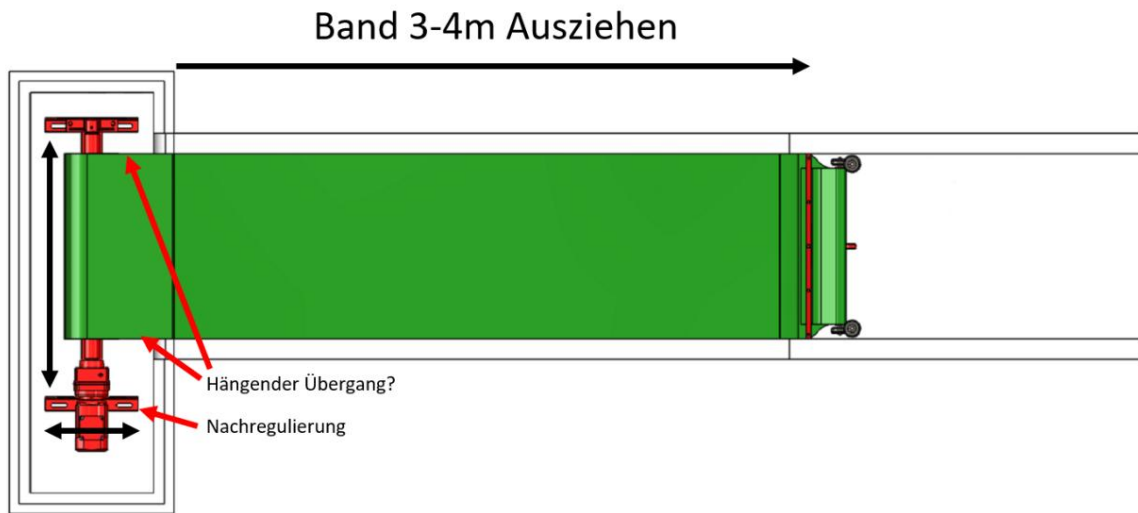


Fig. 24 Assembly of the roll-back device

 **WARNING: Trip hazard and risk of entrapment in the area of the roll-back device**



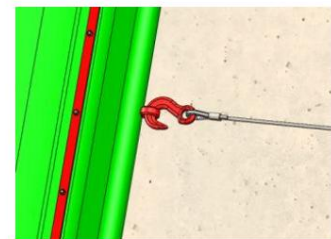
The recessed roll-back device must be secured with a non-slip and non-slip surface.



The system must not be operated without this plate.

4.3 Final assembly:

Pull out the rope and hook it onto the drawbar.



- Setting the end position at the
The winch can be adjusted by moving the rope
stopper.

Precise installation dimensions and electrical installation
Please refer to the installation diagram for details.



Abb. 25 Mounting rope and rope stopper

End board:

- A finishing board (provided by the customer) prevents...
Pollution of the area between winds
and strap. To allow the drawbar to pass underneath,
we recommend a clearance of approximately 10-12
cm without guide rollers and 13-15 cm with a drawbar
that has guide rollers. (See section 3.5.11)



Abb. 26 End board

4.4 Assembly of optional additional components

4.4.1 Reversing device with deflection

The roll-back device

It is attached to the ground with 4 M16x148 bolt anchors and large M16 washers.

The elongated holes allow the return mechanism to be adjusted to the correct angle.

The deflection pulley is also adjusted to the correct height and level using elongated holes.

The belt roller, the deflection mechanism, and the feeding table must be aligned with each other. be as parallel or perpendicular as possible

An example of how the deflection pulley can be enclosed on-site.

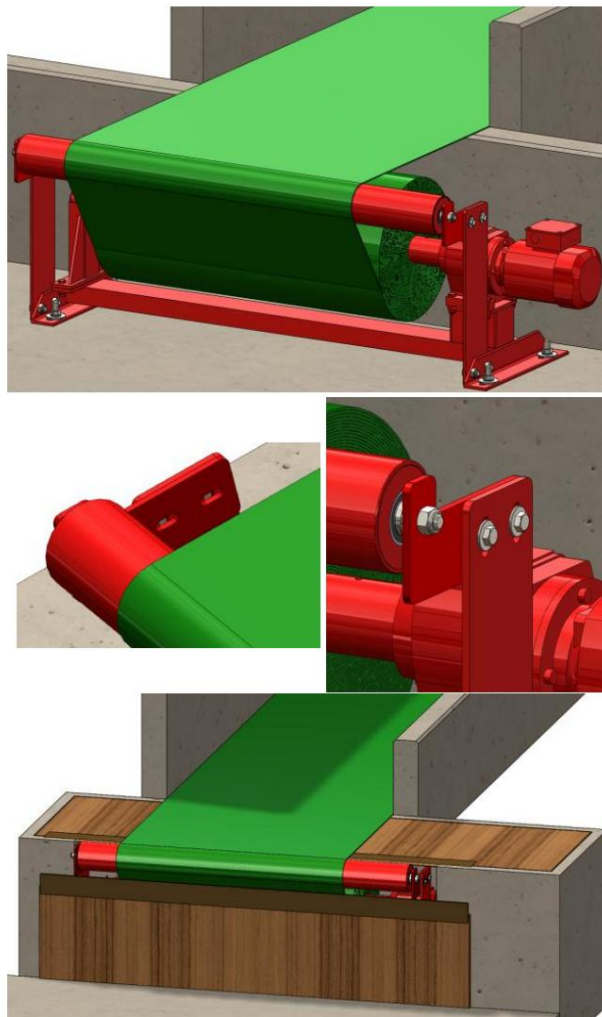


Fig. 27 Assembly of RRV with deflection

4.4.2 Manual residual feed flap

The residual feed flap consists of a standpipe and an aluminum flap with a rubber lip.

The plate's height is 400mm, the length varies depending on the bandwidth.

The standpipe is mounted flush with the inner edge using two M12x110 bolt anchors, ensuring that the gap between the flap and the rebate is approximately 5-7 mm. The flap is simply pushed into place.

Image example for RRV right (left mirror image)

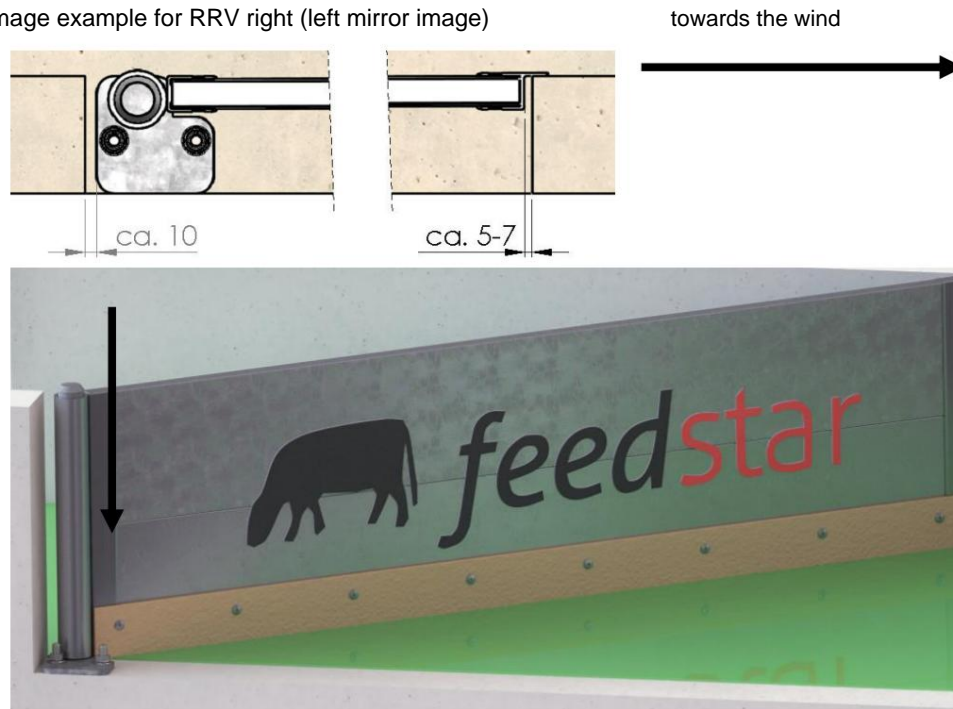


Fig. 28 Assembly of residual feed flap

4.4.3 Sign drawbar

The aluminum sign is screwed to the fixing strips of the drawbar using countersunk screws M8 x 30.

The spacer prevents the sign from tipping over, as it rests on the drawbar. Its height is approximately 400 mm, and its width corresponds to the width of the fixing strips.

(Bandwidth less 150mm)





Fig. 29 Mounting sign drawbar

4.4.4 Rubber lip

The rubber lip has the following dimensions: 200cm x 8.0cm x 0.8cm.

No mounting hardware is included, as the rubber can be attached in a variety of places. The lip may also need to be trimmed. Here are just a few examples:

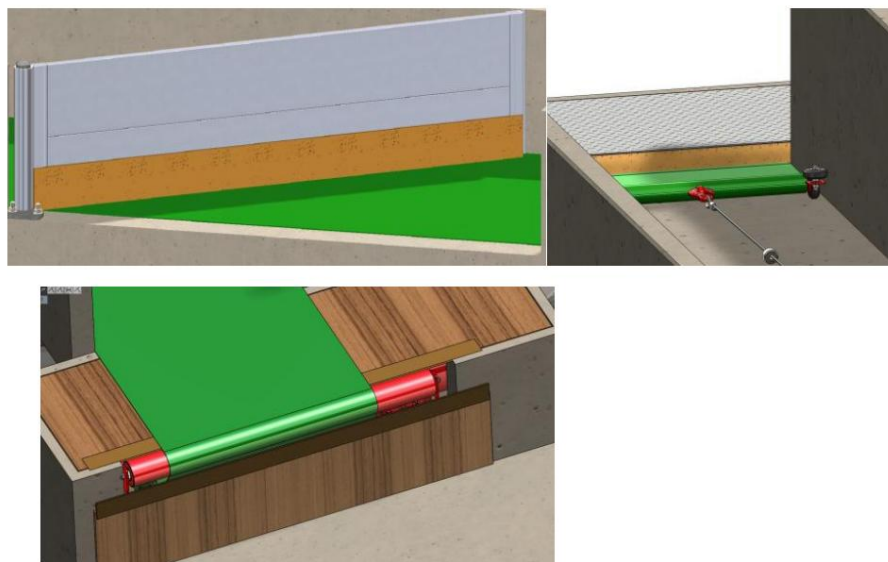


Fig. 30 Mounting rubber lip

4.4.5 Modulwand

The supports are fixed to the ground with Multi Monti using the following dimensions.

The distance from the concrete wall to the outer edge of the support corresponds to the bandwidth.

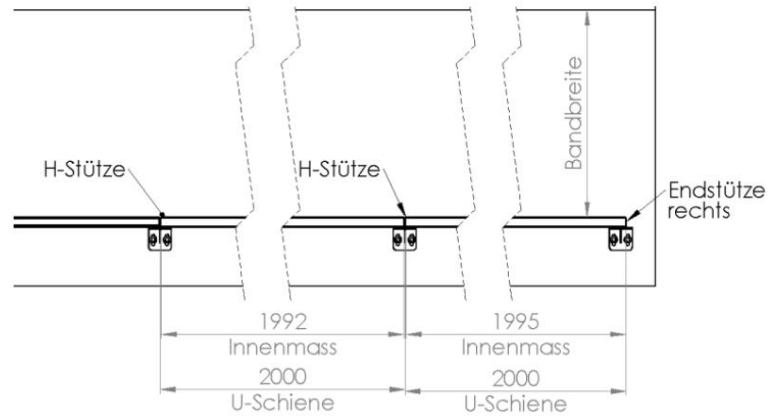


Fig. 31 Assembly of H-supports and end supports

Next, place the U-rail on the floor between the supports and slide the module wall in from above.

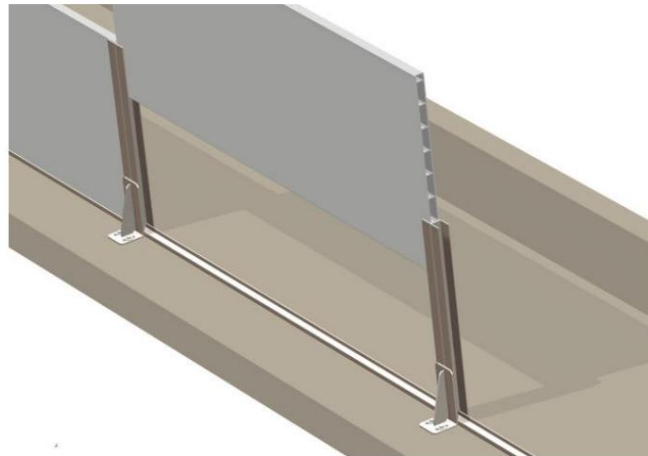


Fig. 32 Inserting the modular wall

4.4.6 Limit switch on the roll-back device

Bring the belt to the position of the end stop, reposition the chain and move the limit switch so that the black metal activates the limit switch when the belt retracts to the stopping point.

The tolerance is approximately 50cm.

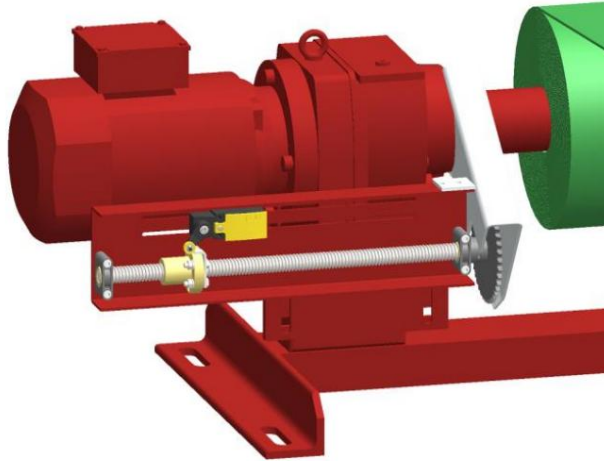


Fig. 33 Limit switch for roll-back device



4.5 Electrical installation

The electrical connection must only be carried out by a qualified electrician, who must ensure, for example, that the winch rotates in the correct direction! The contactors, as well as the on/off switches, are supplied along with the electrical installation plans .

The control system must be protected on - site with a circuit breaker type C or K.

The functions of the shut-off device (limit switch) must be checked before commissioning ! The check must be carried out under load and at low speed to prevent the gearbox from continuing to run.

When mounting the switch box on a wall, comply with the statutory accident prevention regulations.

When mounting the control box on a wall , observe the load-bearing capacity of the wall.

Wall. If the load-bearing capacity of the wall is insufficient: Use a different, statically stable and safe construction.

ÿ Lay the cable in such a way that it does not create any tripping hazards.

Damaged cables (break, crack) must be replaced immediately to prevent personal injury.

The system is now ready for operation.

4.5.1 Conductor cross-sections in relation to the components

The required conductor cross-sections must be calculated by the on-site electrician in each individual case. The following are non-binding suggestions from EDER GmbH.

At:

Protection with circuit breaker type C or K.

	Contactor control	frequency converter
- Main disconnect switch	5 x 2,5mm ² Charakteristik "C" oder "K"	
- Motorleitung Winde Lite11:	4 x 2,5mm ² (YSLY-JZ)	4 x 2,5mm ² (YSLYCY-JZ) <u>shielded</u>
- Winch limit switch	3 x 1,5mm ²	
- Emergency stop circuit	3 x 1,5mm ²	
- Motor cable roll-back device RRV 1	4 x 2,5mm ² (YSLY-JZ)	4 x 2,5mm ² (YSLYCY-JZ) <u>shielded</u>
- Emergency stop circuit	3 x 1,5mm ²	
- Control line button	9 x 1,5mm ² (YSLY-JZ)	
- Limit switch RRV	3 x 1,5mm ²	
- - Safety switch RRV	3 x 1,5mm ²	

All electrically conductive parts and all metallic components must be included in the equipotential bonding system!

4.5.2 Connecting the radio remote control

The radio remote control can be retrofitted at any time.

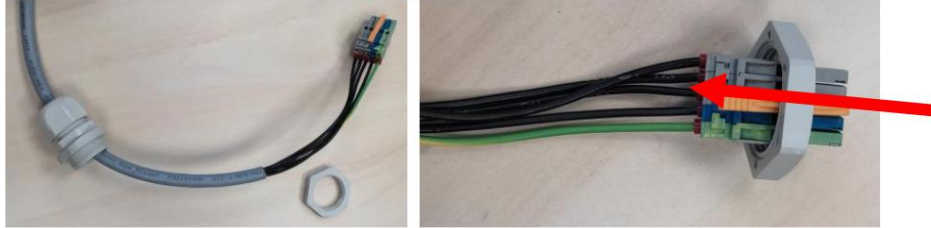


Fig. 34 Receiver connection cable with strain relief

Feed the connecting cable with strain relief through the base plate, then slide the lock nut over the plug.

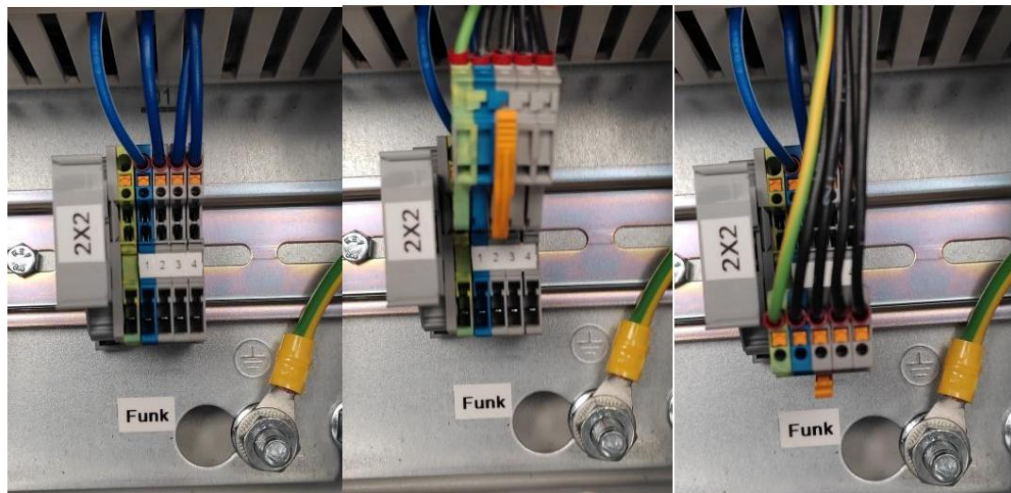


Fig. 35 Plug connection receiver to terminal 2X2

Then simply plug the connector into terminal 2X2.



5 Operation

When operating the system, the safety instructions mentioned in Chapter 2.3 and the warnings mentioned in Chapter 2.4 must be strictly observed – this will prevent life-threatening injuries, machine damage and other property damage.

Familiarize yourself with the system before starting work. It will be too late once you're working!

ÿ Before each operation, check that the rope, the conveyor belt, and the electrical components (especially the limit switches and deadman's switch) are in proper working order. This check must be carried out under load and at low speed to prevent the gearbox from continuing to run.

If the cable drum continues to run over, check the brake pads for Oil contamination. Clean or replace the pads if necessary.

Check the safety devices for proper functioning before each use.

If you notice any safety-relevant changes, do not put the system into operation! First, ensure all protective devices are in proper working order.

ÿ Ensure that no obstacles can get into the path of the pull, as this could increase the pulling force and lead to a rope or strap breakage.

ÿ Switch on the system at the main switch (see Fig. 17).

ÿ From a fill level of approximately 60%, the belt must be driven through to the end stop, otherwise restarting the winch may fail due to overload.

The plant is now operational.

5.1 Filling the Feedstar

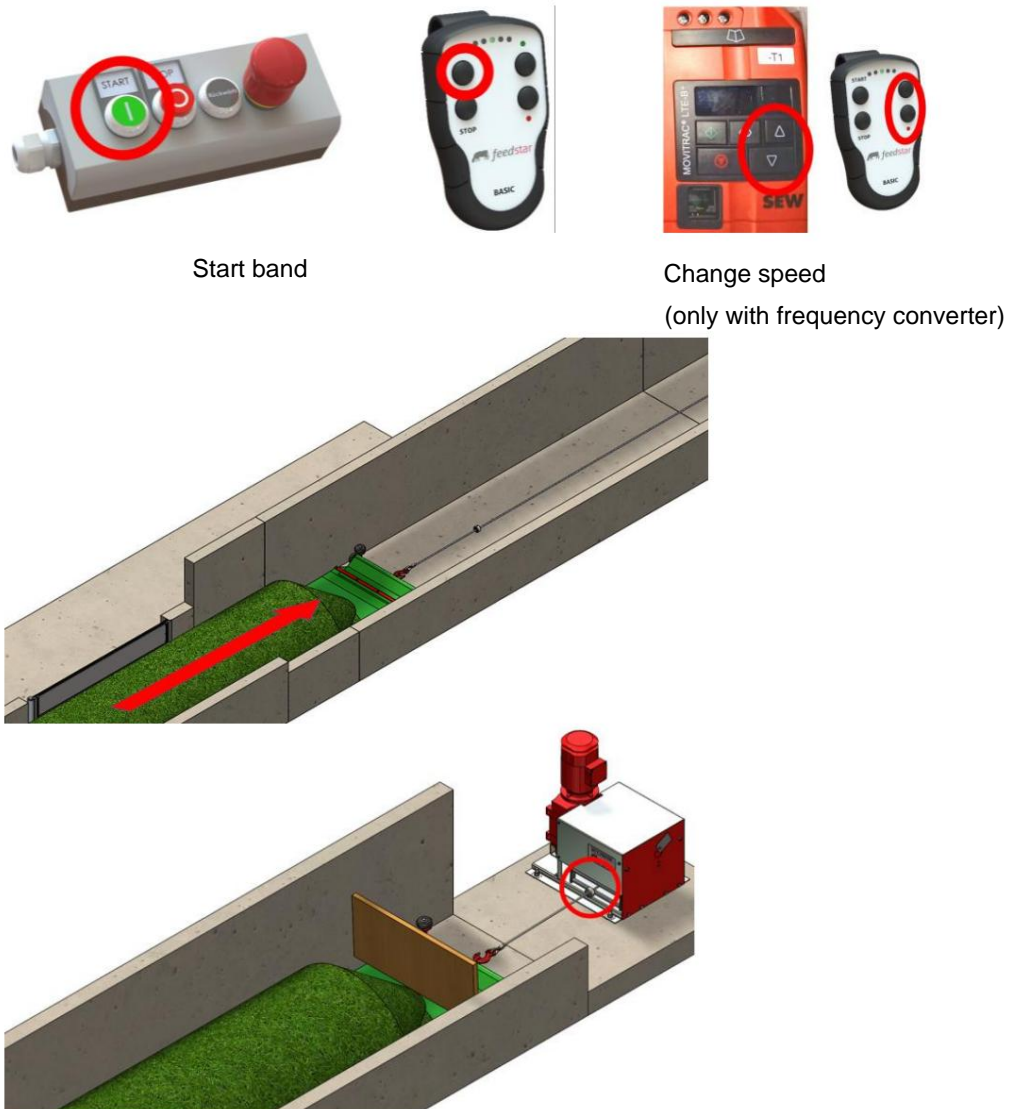


Fig. 36 Filling the Feedstar

Let the feed belt run into the barn (see 3.6 Control unit).

Slowly tip feed from a storage container or filling device onto the conveyor belt.

Adjust the fill quantity using your filling device. The system will operate at a constant level .

Speed on.

Fill the belt evenly and , once it is 2/3 full, run it continuously until it reaches the limit switch. Avoid stopping and restarting with a full belt.

- The system has an automatic shut-off. As soon as the belt is fully inside the barn
Once the flow rate has reached zero, the system stops automatically.
- A finishing board (provided by the customer) prevents the area between the winch and the belt from becoming dirty. To allow the drawbar to pass underneath, we recommend a clearance of approximately 10-12 cm without guide rollers and 13-15 cm with guide rollers.

Then stop the filling process.

5.2 Emptying the Feedstar



Tape Reverse

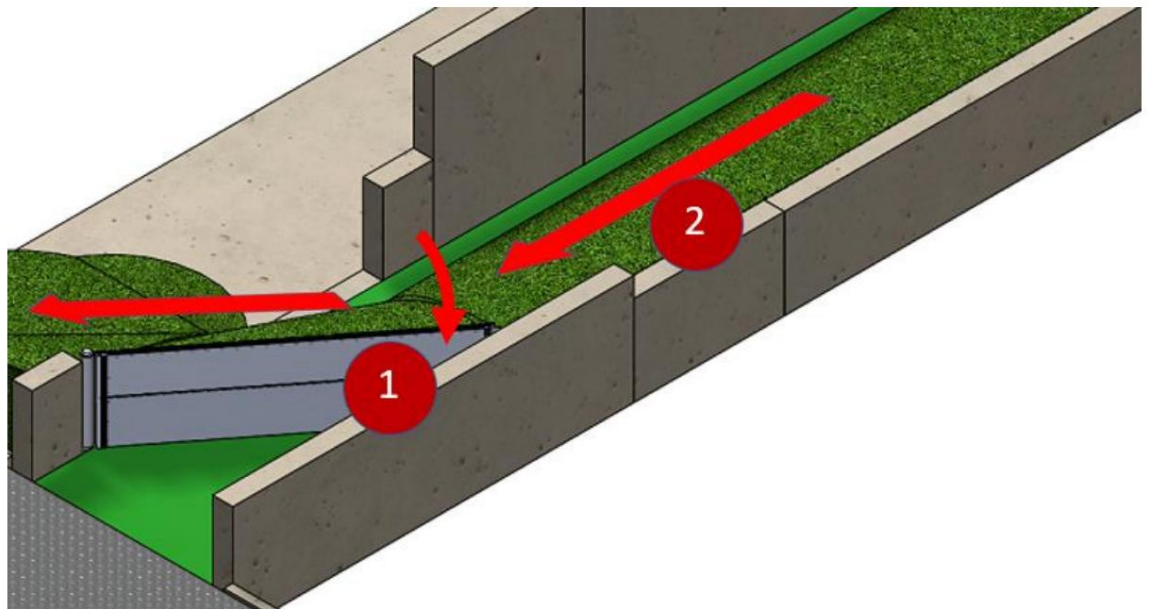


Fig. 37 Emptying the Feedstar

- (1) Open the residual feed flap (optional, see Fig. 8) to empty the remaining feed into to collect in the bottom tray.
- (2) Let the conveyor belt run out of the barn. Avoid stopping and restarting it.

ŷ Is the roll-back device equipped with an end stop (optional, see Fig. 10), the system stops automatically as soon as the belt has run out of the barn.

Close the residual feed flap.

The system is ready for the next filling.

6 Disturbances

When troubleshooting, the safety instructions mentioned in Chapter 2.3 and the warnings mentioned in Chapter 2.4 must be strictly observed. This will prevent life-threatening injuries, machine damage and other property damage.

Hotline telephone number (also available on weekends): 0175 2602376

Mistake	Caused	Fix
The feed belt jerks when entering the Stall	There is an obstacle in the track.	Remove the obstacle.
The belt is not moving. The main switch is in position "O".	Emergency stop pressed	Turn on the system. Check the emergency stop switch
	There is an obstacle in the track.	<small>to have</small> Remove the obstacle.
	The rope is not connected to the drawbar or is broken.	Connect the rope to the pull beam if it still has sufficient length. Otherwise, replace the rope.
	The remote control batteries are too weak	Replace the batteries in the remote control operation.
	The motor or cable is defective.	Switch off the system, check the lines for breaks (corroded?) and call the Eder GmbH service hotline.
The engine is making unusual noises.	The motor or chain drive is defective.	Switch off the system and call the service hotline of Eder GmbH.
Wind runs towards	belt not loaded brake pads oily or worn out	Tire loaded Degrease brake pads, check spring tensioning or renewing linings

7 Maintenance and inspection

7.1 General Information

When maintaining and servicing the system, the safety instructions mentioned in Chapter 2.3 and the warnings mentioned in Chapter 2.4 must be strictly observed – this will prevent life-threatening injuries, machine damage and other hazards.

Property damage avoided.

Cleaning and maintenance work may only be carried out by authorized operating personnel - the operating instructions must be strictly followed.

Spare parts must at least meet the technical requirements specified by the device manufacturer.

Maintenance, cleaning and repair work should only be carried out with the drives stopped and the main switch switched off.

All work on the electrical equipment of the machine may only be carried out by trained electrical specialists.

A NOTICE

After completing maintenance or repairs, ensure that no tools, cleaning materials, or other parts remain in the system.
it.

A NOTICE

Please note, in your own interest, that any necessary repairs or maintenance beyond the scope of this technical documentation during the warranty period can only be carried out by Eder GmbH itself.

7.2 Maintenance plan

Task	weekly	quarterly as needed	
Check the rope and pull-in tape for wear (especially) Rope inlet with retracted rope and rubber lip on the (Feeding table entrance)	x		
Cleaning the system		x	
Lubricating the drives Winch: 1 grease nipple on the side of the winch Retractable device: all existing grease nipples		x	
If a limit switch is present on the reverser: lubricate the spindle.			x semi-annually

7.3 Gear oil

Gear oil CLP VG220 – Oil check screw cross-check:

Gear quantities:

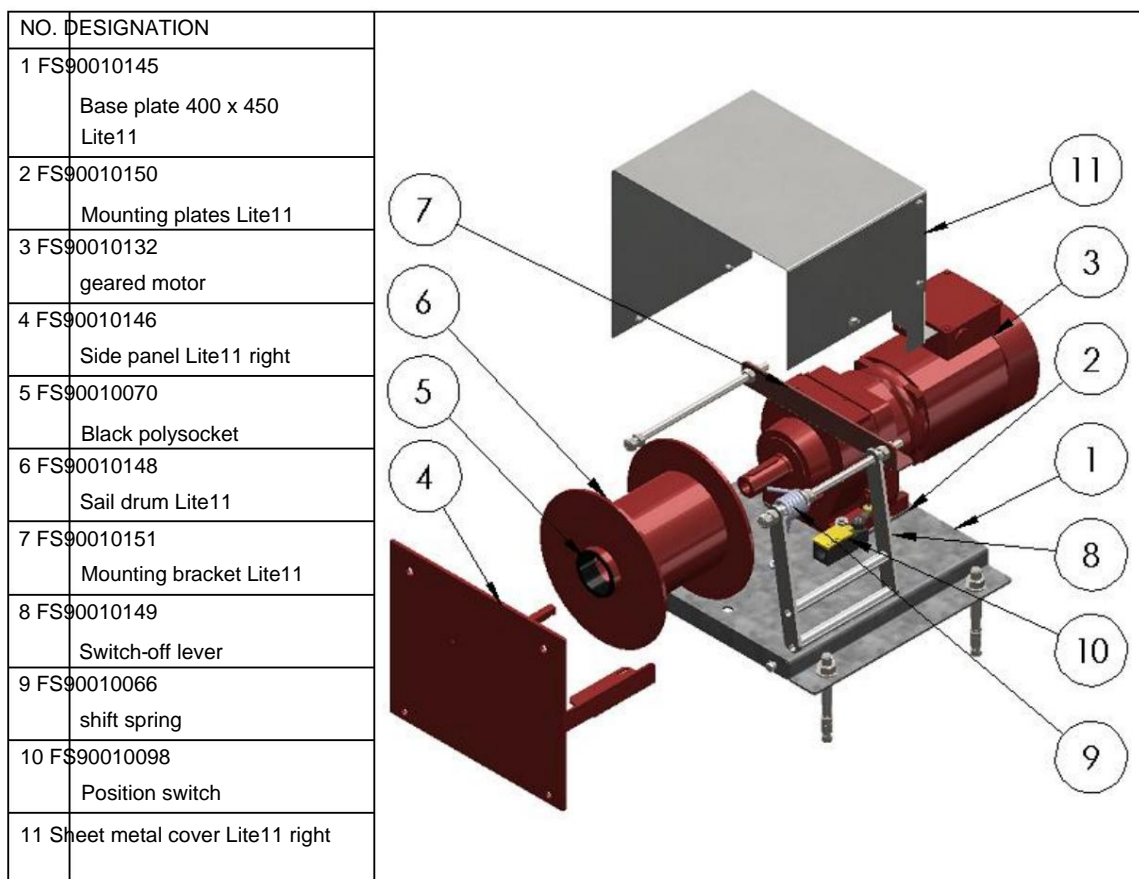
- Winch Lite11 and rewind device A1

G33A gearbox

0,35ltr.

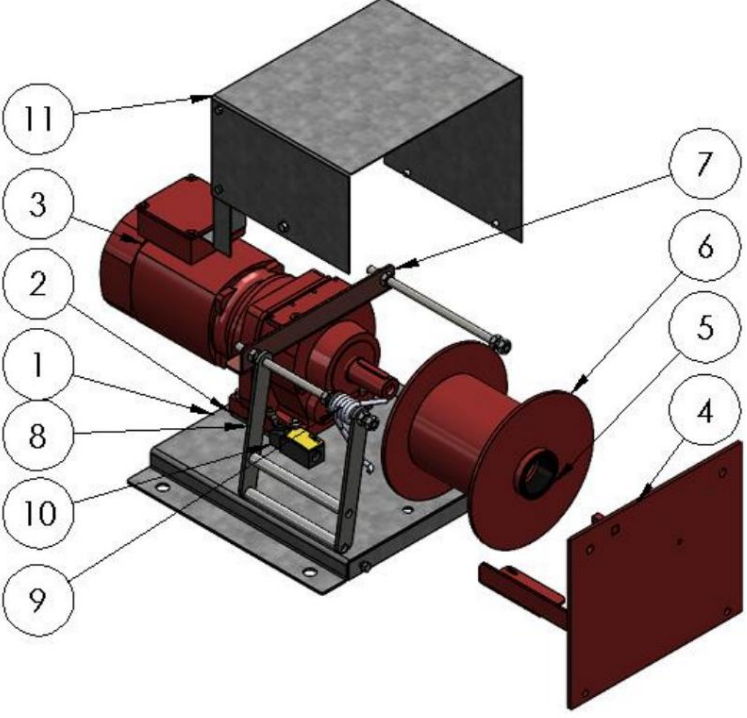
7.4 Exploded Views

7.4.1 Winch Lite11 right



7.4.2 Winde Lite11 links

NO.	DESIGNATION
1	FS90010145 Base plate 400 x 450 Lite11
2	FS90010150 Mounting plates Lite11
3	FS90010132 geared motor
4	FS90010152 Side panel Lite11 left
5	FS90010070 Black polysocket
6	FS90010148 Sail drum Lite11
7	FS90010151 Mounting bracket Lite11
8	FS90010149 Switch-off lever
9	FS90010066 shift spring
10	FS90010098 Position switch
11	Sheet metal cover Lite11 left



7.5 Repairs

A NOTICE

Necessary repairs must only be carried out by authorized and appropriately trained specialists. Accident prevention regulations must be observed.



8. Removal and decommissioning

When dismantling and decommissioning the system, the safety instructions mentioned in Chapter 2.3 and the warnings mentioned in Chapter 2.4 must be strictly observed – this will prevent life-threatening injuries, machine damage and other property damage.

The decommissioning of the system may only be carried out by qualified persons in compliance with the safety instructions.

8.1 Decommissioning

To temporarily shut down the system, it must be switched off at the main switch.
switch.

8.2 Final decommissioning

In addition to the points mentioned above, securing the main switch against being switched back on must also be observed for the final decommissioning.

9 Recycling and Disposal

The plant consists largely of valuable, recyclable materials that are intended for recycling. Its modular design allows for easy disassembly into its component parts.

Ensure that all applicable laws, standards, regulations and regional rules are followed when disposing of the equipment.

Take the system completely out of service.

Separate the disassembled parts according to recyclable materials.

Ensure that the parts to be disposed of and any accessories are disposed of properly.

Once the plant has reached the end of its life cycle, its dismantling must ensure safe and proper disposal, especially of parts or substances that are harmful to the environment. care for.

INFORMATION

We recommend that you entrust the disposal of your machine to a certified regional specialist company.

10 Declaration of Conformity

EG-Konformitätserklärung

im Sinne der EG-Maschinenrichtlinie 2006/42/EG, Anh. II 1. A

Hersteller

EDER GmbH
Moorweg 5
DE - 83104 Tuntenhausen

In der Gemeinschaft ansässige Person, die bevollmächtigt ist, die technischen Unterlagen zusammenzustellen

Geschäftsführer
EDER GmbH
Moorweg 5
DE - 83104 Tuntenhausen

Beschreibung und Identifizierung der Maschine

Produkt / Erzeugnis	Futterband
Type	Feedstar basic und vario
Seriennummer	200 bis folgende
Handelsbezeichnung	Futterband
Funktion	Aus einem Vorratsbehälter wird Grünfütter oder Mischration auf ein Futterband gekippt. Durch eine Seilwinde wird das beladene Futterband gleichmäßig in einem Futtertrog über die gesamte Länge der Fütterungszone gezogen. Die Abschaltung der Seilwinde erfolgt über einen Endschalter an der Seilwinde. Nach Beendigung der Fresszeit wird das Futterband von einem Bandrückführsystem aufgewickelt. Evtl. vorhandenes Restfütter wird von einem beweglichen Abstreifer (Gurtreinigung) in eine Auffanggrube neben dem Futterband befördert.

Es wird ausdrücklich erklärt, dass die Maschine allen einschlägigen Bestimmungen der folgenden EG-Richtlinien bzw. Verordnungen entspricht:

2006/42/EG	Richtlinie 2006/42/EG des Europäischen Parlaments und des Rates vom 17. Mai 2006 über Maschinen und zur Änderung der Richtlinie 95/16/EG (Neufassung) (1) Veröffentlicht in L 157/24 vom 09.06.2006
2014/30/EU	Richtlinie 2014/30/EU des Europäischen Parlaments und des Rates vom 26. Februar 2014 zur Harmonisierung der Rechtsvorschriften der Mitgliedstaaten über die elektromagnetische Verträglichkeit (Neufassung) Veröffentlicht in L 96/79 vom 29.03.2014

Fundstelle der angewandten harmonisierten Normen entsprechend Artikel 7 Absatz 2:

EN ISO 12100:2010-11	Sicherheit von Maschinen - Allgemeine Gestaltungsleitsätze - Risikobewertung und Risikominderung (ISO 12100:2010)
EN ISO 13857:2008	Sicherheit von Maschinen - Sicherheitsabstände gegen das Erreichen von Gefährdungsbereichen mit den oberen und unteren Gliedmaßen (ISO 13857:2008)
EN 14492-1:2006+A1:2009/AC:2010	Krane - Kraftgetriebene Winden und Hubwerke - Teil 1: Kraftgetriebene Winden
EN 60204-1:2006/AC:2010	Sicherheit von Maschinen - Elektrische Ausrüstung von Maschinen - Teil 1: Allgemeine Anforderungen
EN 620:2002+A1:2010	Stetigförderer und Systeme - Sicherheits- und EMW-Anforderungen für ortsfeste Gurtförderer für Schüttgut
EN 1037:1995+A1:2008	Sicherheit von Maschinen - Vermeidung von unerwartetem Anlauf
EN ISO 14120:2015	Sicherheit von Maschinen - Trennende Schutzeinrichtungen - Allgemeine Anforderungen an Gestaltung, Bau und Auswahl von feststehenden und beweglichen trennenden Schutzeinrichtungen (ISO 14120:2015)
EN ISO 13849-1:2015	Sicherheit von Maschinen - Sicherheitsbezogene Teile von Steuerungen - Teil 1: Allgemeine Gestaltungsleitsätze (ISO 13849-1:2015)
EN ISO 13850:2015	Sicherheit von Maschinen - Not-Halt - Gestaltungsleitsätze (ISO 13850:2015)
EN 60204-1:2006/A1:2009	Sicherheit von Maschinen - Elektrische Ausrüstung von Maschinen - Teil 1: Allgemeine Anforderungen

Tuntenhausen, 07.07.2018
Ort, Datum

EDER
GmbH • Moorweg 5
83104 Tuntenhausen
Tel. 08067/181-0 / Fax 181-782
Unterschrift
Georg Pfeilschifter
Geschäftsführer