

Operating manual

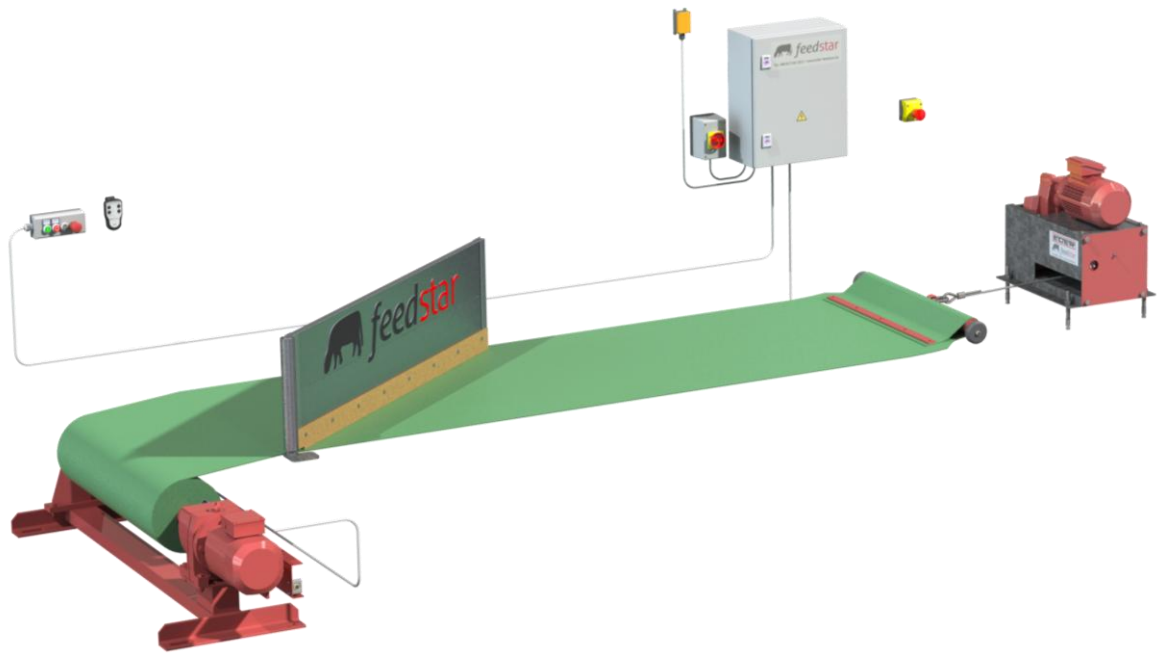

feedstar Lite33

Octobre 2025

Eder GmbH
Moorweg 5
83104 Tuntenhausen

Tel. +49 8067 181-822
Web www.feedstar.com
Mail feedstar@eder-gmbh.de

Revision				
Date	Version	Chapter	Reason	Responsible
14.10.2025	V01R02	All	Translation	Markus Grad – Eder GmbH

All information and drawings were up to date at the time of printing.

This operating manual was created according to our best knowledge. If you discover errors or unclear areas nevertheless, we will ask you to inform us. Furthermore, we would be happy to receive your comments and suggestions.

Subject to technical changes.

Type label:

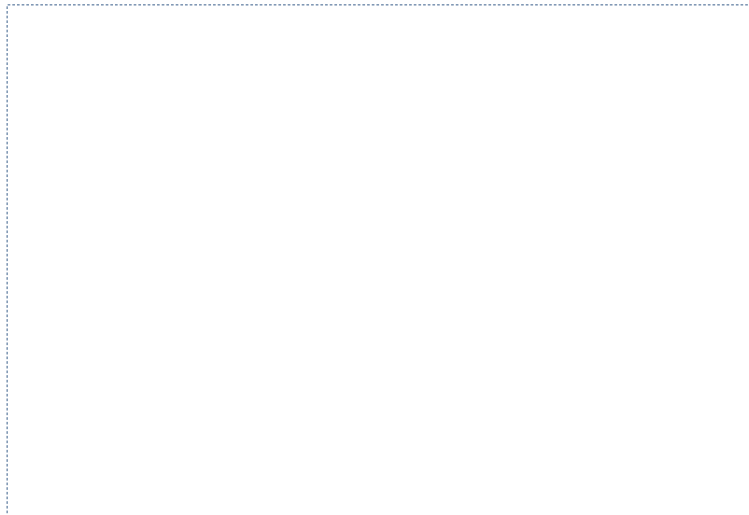

This operating manual is the property of

Eder GmbH
Moorweg 5
83104 Tuntenhausen

Reproduction, copying and translation – even as extracts - of the operating manuals of Eder GmbH is only permitted with our prior consent and with reference to the source.

Tuntenhausen, 10th October 2023

Table of Contents

1	Notes regarding the documentation	6
1.1	Purpose.....	6
1.2	Liability	6
1.3	Target group	7
1.4	Display of information	7
1.5	Setup and structure of the safety and warning information	7
1.6	Storage of the documents	8
1.7	Validity of the manual	8
2	Safety	9
2.1	Classification of the action-related warning information	9
2.2	Machine stickers, warning, prohibition and mandatory signs	10
2.3	General safety information	11
2.4	Warning information	12
2.4.1	Complete system	12
2.4.2	Hazards in the area of the Feedstar	15
2.4.3	Hazards for people and animals from feed and auxiliary substances.....	16
2.4.4	Hazards during transport	17
2.5	General protective measures	18
2.6	Personal protective equipment.....	18
2.7	Obligations of the operator.....	19
2.8	Training of the personnel	19
2.9	Protection devices / EMERGENCY STOP button.....	20
3	Functional description	21
3.1	Use as intended	21
3.2	Foreseeable incorrect use	21
3.3	Retrofitted components.....	21
3.4	Design of the Feedstar Lite33.....	22
3.5	Optional additional components	23
3.5.1	Lateral guide rollers on the pull bar	23
3.5.2	Back roll device with deflection pulley.....	23
3.5.3	Steel cover with under beam	24
3.5.4	Residual feed flap manual	25
3.5.5	Shield pull bar	26
3.5.6	Limit switch on back-roll-device.....	26
3.5.7	Module wall system	27

3.5.8	Precast concrete elements.....	27
3.5.9	End board (on-site).....	28
3.6	Control unit	29
3.7	Control box.....	30
3.8	Type plate.....	30
3.9	Technical specifications.....	30
4	Mounting	31
4.1	Mounting of the winch.....	31
4.2	Mounting the back roll device:.....	32
4.3	Final mounting:.....	34
4.4	Mounting optional additional components	35
4.4.1	Back roll device with deflection	35
4.4.2	Residual feed flap manual.....	36
4.4.3	Shield pull bar.....	36
4.4.4	Rubber lip.....	37
4.4.5	Module wall.....	38
4.5	Elektrische Installation	39
4.5.1	Cable cross-sections in relation to components	40
4.5.2	Connecting the radio remote control.....	41
5	Operation	42
5.1	Feedstar befüllen.....	43
5.2	Emptying Feedstar.....	44
6	Faults.....	45
7	Maintenance and inspection.....	46
7.1	General Information.....	46
7.2	Maintenance plan.....	46
7.3	Gear oil	47
7.4	Exploded view	47
7.5	Repairs.....	47
8	Removal and decommissioning.....	48
8.1	Decommissioning	48
8.2	Final decommissioning	48
9	Recycling and disposal	49
10	Declaration of Conformity (German version)	50

List of figures

Fig. 1	EMERGENCY STOP button in the area of the winch	20
Fig. 2	EMERGENCY STOP on the external button	20
Fig. 3	Feedstar, schematic overall view	22
Fig. 4	Lateral guide rollers on the pull bar (optional)	23
Fig. 5	Back roll device with deflection pulley (optional).....	23
Fig. 6	Steel cover with under beam (optional)	24
Fig. 7	Residual feed flap manual (optional)	25
Fig. 8	Shield pull bar.....	26
Fig. 9	Limit switch on back-roll-device.....	26
Fig. 10	Modular wall system installed	27
Fig. 11	Precast concrete elements.....	28
Fig. 12	End board for winch (on-site)	28
Fig. 13	External button	29
Fig. 14	Remote control (optional).....	29
Fig. 15	Control box and main disconnect switch	30
Fig. 16	Type plate.....	30
Fig. 17	Mounting winch Lite33	31
Fig. 18	Dimensions back roll device	32
Fig. 19	Fastening back roll device	32
Fig. 20	Belt infeed back-roll-device.....	32
Fig. 21	Mounting back roll device.....	33
Fig. 22	Limit swich back-roll-device	33
Fig. 23	Mounting wire.....	34
Fig. 24	End board	34
Fig. 25	Mounting BRD with deflection.....	35
Fig. 26	Mounting the residual feed flap.....	36
Fig. 27	Mounting shield pull bar	37
Fig. 28	Mounting rubber lip	37
Fig. 29	Assembly of H-props and end supports	38
Fig. 30	Inserting the module wall	38
Fig. 31	Receiver connection cable with strain relief.....	41
Fig. 32	Plug connection receiver to terminal 2X2.....	41
Fig. 33	Filling the feedstar.....	43
Fig. 34	Emptying Feedstar.....	44

1 Notes regarding the documentation

1.1 Purpose

This operating manual should help you to become familiar with the system and to achieve the full functional benefit from its high performance.

The operating manual contains important information for the safe, correct and effective use of the system. The instructions must be complied with carefully, in order to avoid risks, reduce repair costs and downtime, and to increase the reliability and service life of the system.

Persons who are responsible for the installation, commissioning, operation or maintenance of the system must have read, understood and comply with the operating manual. For this reason, it must be always kept at the location of the system. The local safety and accident prevention regulations and the chapter "safety" (see Chapter 2) must be complied with.

1.2 Liability

In the case of damage and operating faults which are due to non-compliance with the operating manual, Eder GmbH accepts no liability.

Independent changes and modifications on the system are prohibited for safety reasons. If changes or modifications to the system do not have express approval from Eder GmbH, then the operating permit expires, and no liability is accepted for resulting damage

Such changes include, for example:

- Removal of protective equipment
- Changing the belt length/width
- Changing belt speeds

In the case of damage, which is attributable to such interventions, Eder GmbH accepts no liability. The operating permit expires. The risk is borne by the user alone!

We reserve the right to apply the latest technical changes which serve further development and improvement of the system and technical progress.

1.3 Target group

This operating manual is intended for the following target groups:

- trained operating personnel
- trained maintenance personnel

1.4 Display of information

To ensure that you can work with this manual quickly and safely, uniform formatting, numbering, symbols, safety information (see chapter 2.1), terms and abbreviations are used.

▶ Action instructions are identified by an arrow ▶.

- Lists are identified with bullet points.

NOTE

Here you receive information, in order to avoid possible damage.

INFORMATION

Here you will receive useful information regarding the product in general or for handling.

1.5 Setup and structure of the safety and warning information

The safety information items in this operating manual are structured according to a uniform scheme. They denote residual risks which can cause injuries or damage.

General structure



(Warning symbol)

Type and source of the hazard.

Consequences if not complied with

- ▶ Measures for hazard avoidance

The following applies:

Warning symbol: draws attention to the hazard

Signal word indicates the severity of the hazard

The safety instructions follow action instructions. The action instructions must be complied with for safety protection.

1.6 Storage of the documents

This operating manual and all the documents applicable must be stored for all persons operating on the system in such a way that they are ready for use at any time. The location of the documents must be identifiable for these persons.

1.7 Validity of the manual

This operating manual is exclusively valid for the Feedstar Lite33 from Eder GmbH.

2 Safety

When the machine is used, during fault rectification and maintenance, please note the warning signs and symbols which are identified for each action, and all safety signs which are attached to the machine.

2.1 Classification of the action-related warning information

DANGER

Indicates a directly hazardous situation which leads to death or serious injuries in the event of non-compliance.

Consequences if not complied with

- ▶ Measures for hazard avoidance

WARNING

Indicates a potentially hazardous situation which can lead to death or serious injuries in the event of non-compliance.

Consequences if not complied with

- ▶ Measures for hazard avoidance

CAUTION

Indicates a potentially hazardous situation which can lead to minor or light injuries in the event of non-compliance.

Consequences if not complied with

- ▶ Measures for hazard avoidance

2.2 Machine stickers, warning, prohibition and mandatory signs

The information and safety signs attached to the system must be complied with. They must not be changed or removed. Damaged signs must be replaced immediately. The following list serves as an explanation of symbols in this manual or on the machine.

Information and warning signs



Warning of
Hazard location



Warning of dangerous elec-
trical voltage



Warning of
Entanglement hazard



Warning of
Hand injuries



Warning of
automatic start-up



Warning of
hot surfaces



Warning of falling hazard

Mandatory symbol



isolate before work!



Use eye protection!



Follow the manual!



Wear protective gloves!



Use foot protection!

2.3 General safety information

Knowledge of the basic safety information and safety requirements is the prerequisite for safe use and trouble-free operation of the machine.

This operating manual contains all important information in order to operate the system safely.

The system must be protected against access by unauthorised persons.

The company-internal work protection requirements must be complied with.

NOTE

Operating the system without safety equipment is negligent and does not fall into the area "foreseeable incorrect use"!

This operating manual does therefore not explicitly use warning signs and symbols to identify hazards which can occur with a safety device removed.

Residual risks

Residual risks are risks which, despite a safe design and technical protection equipment, represent an unavoidable, non-obvious risk, which is not apparent from the use of the product.

NOTE

To prevent residual risks, all safety information in this operating manual must be complied with.

During all work, the statutory and occupational trade body requirements regarding occupational safety and accident prevention must be complied with.

Work on the system must only be performed by trained and familiarised specialist personnel.

Independent modifications

Independent modifications can cause hazards to emanate from the Feedstar. Changes, attachments or modifications which can impair the safety must not be made.

2.4 Warning information

2.4.1 Complete system

WARNING

Hazard from manipulation of safety measures and equipment

- ▶ Do not make changes to the system.
- ▶ Modifications on the machine must be approved in writing by the manufacturer.
- ▶ Do not manipulate protective devices.
- ▶ Only operate the machine if all protective devices are properly installed and working.

WARNING



Electrical hazard from indirect contact with parts which have become live due to faulty states

- ▶ Work on the electrical equipment must only be performed by authorised specialist personnel.
- ▶ Only carry out maintenance and retrofitting work on the machine if it is disconnected from the power supply.
- ▶ Switch the machine off at the main switch and secure it against re-switching.
- ▶ Place a sign "Do not switch on machine".
- ▶ Clean electrical equipment regularly and check for damage.
- ▶ Cables must not be clamped or squeezed.
- ▶ Cables must be installed in such a way that they cannot cause tripping hazards or can be damaged.
- ▶ Fix loose connections.
- ▶ Change damaged cables immediately.

WARNING

Hazards from movements of the system components

If the system is switched on during the repair or if the repair is performed with the system running, then it can cause serious or fatal injuries.

- ▶ When working on the system, it is necessary that the system is completely switched off and is secured, for example, against switching back on by means of a lock.
- ▶ Before switching on, make sure that no persons are located within the hazard area.
- ▶ Wear the prescribed personal protective equipment
 - Safety shoes
 - Protective gloves
 - Safety helmet for overhead works

! WARNING

Hazard from automatic start-up

- ▶ Only use the system with functional protective devices.
- ▶ Protection devices must not be removed or manipulated.

! WARNING
Hazard from the missing possibility of switching off the system as quickly as possible in an emergency

- ▶ Location and function of the emergency-stop devices and the procedure in case of emergency must be known to all persons working on the system.
- ▶ The emergency stop devices must always be accessible.
- ▶ In no circumstances must emergency stop devices must be blocked by items, be fixed or used as a hook.
- ▶ After repair work, it must be ensured that all emergency stop devices are functional.

! WARNING
Risk of injury from the structural failure of system components due to corrosion
Mechanical hazard from incorrectly dimensioned or faulty machine parts / static strength
Hazard from breaking components

- ▶ Note the information regarding the intended use for the automatic feeding system.
- ▶ Check the mechanical and electrical components regularly for damage, if necessary, replace damaged parts.
- ▶ Ensure completeness and legibility of all safety and hazard information.
- ▶ Comply with the maintenance intervals.
- ▶ Replace damaged or missing corrosion protection.
- ▶ Wear the prescribed personal protective equipment
 - Safety shoes
 - Protective gloves
 - Safety helmet for overhead works

! WARNING
Hazards from incorrect installation and incorrect or non-approved spare parts

- ▶ If components are replaced, only use original parts or parts approved by the manufacturer.
- ▶ The work must only be performed by trained specialist personnel.

 CAUTION

Risk of injury from contact with hot surfaces (motor, bearings, drives)

- ▶ allow motors, bearings and drives to cool before working on the machine.
- ▶ Wear heat-resistant protective gloves.

 CAUTION

Hazards from unsuitable design, placement or identification of operating elements and displays

- ▶ Keep displays and operating parts clean and legible.
- ▶ Replace incorrect labels immediately.
- ▶ Ensure the labelling of the operating parts and warning signs and symbols are in the operator's language.
- ▶ If necessary, label additionally in the operator's language.

 CAUTION

Hazard from direct contact with, breakdown, arcs, fire or short circuit of live parts, produced by the electrical equipment of the system

- ▶ Work on the electrical equipment must only be performed by authorised specialist personnel.
- ▶ Work on the system must only be performed in the voltage-free state, in compliance with the safety rules.
- ▶ Only carry out maintenance and retrofitting work on the machine if it is disconnected from the power supply.
- ▶ Switch the machine off at the main switch and secure it against re-switching
- ▶ Place a sign "Do not switch on machine".
- ▶ Clean electrical equipment regularly and check for damage.
- ▶ Cables must not be clamped or squeezed.
- ▶ Cables must be installed in such a way that they cannot cause tripping hazards or can be damaged.
- ▶ Fix loose connections.
- ▶ Change damaged components immediately.
- ▶ Do not operate the machine if damage is present.

 CAUTION

Hazard to health possible in the event of working on system components under severe environmental conditions outside of buildings

- ▶ Wear suitable clothing for the environment.

 CAUTION
Hazards from noise in the area of the drives

- ▶ Carry out noise measurements.
- ▶ For values above 80 dBA, wear suitable hearing protection.

2.4.2 Hazards in the area of the Feedstar
 WARNING
Hazard from breaking components if the winch or the back roll device do not switch off

- ▶ Only operate the system with functional protective equipment.
- ▶ The function of the switch-off device must be checked before commissioning.

 WARNING
Hazard from cutting, rubbing or abrasion**Hazard from rubbing or abrasion on the wire of the winch**

- ▶ Check the wire regularly for damage, if necessary, change.

 WARNING
**Hazard from trapping of limbs, entanglement or trapping, being caught in the area of the back roll device**

- ▶ Only carry out work in manual operation and repairs only if the power is disconnected from the system power supply.
- ▶ Only operate the system with functional protective equipment.
- ▶ Use suitable lifting devices for opening the shaft cover.
- ▶ Before switching on, make sure that no persons are located within the hazard area.

 WARNING
**Hazard from crushing of limbs in the area of the winch and the optional belt cleaning****Hazard from drawing in, trapping or being caught in the area of the winch**

- ▶ Work on the system must only be performed by trained and familiarised specialist personnel
- ▶ Only operate the system with functional protective equipment.
- ▶ Only carry out work during manual operation of the system.
- ▶ When working on the system, it is especially important that the system is completely switched off and is secured, for example, against switching back on by means of a lock.
- ▶ Before switching on, make sure that no persons are located within the hazard area.

2.4.3 Hazards for people and animals from feed and auxiliary substances

! WARNING**Hazard to health from contact with lubricants and cleaning**

- ▶ Avoid skin contact with lubricating and cleaning agents where possible.
- ▶ After contact with lubricating and cleaning agents, immediately clean skin areas and change contaminated clothing.
- ▶ Do not allow lubricating and cleaning agents to enter the environment.
- ▶ Remove and dispose of leaked substances immediately using a suitable binder.
- ▶ Dispose of lubricating and cleaning agents in accordance with the environmental requirements.

! WARNING**Risk of environmental damage from used substances and materials**

- ▶ Dispose of the substances and materials used (greases, oils, cleaning or solvent materials) in accordance with the statutory provisions.

! WARNING**Risk of injury from slipping, stumbling and falling during weather-related slippery conditions or during cleaning and maintenance work, for example from feed residues**

- ▶ Traffic routes in the internal and external areas of the feed system must always be kept ice- and snow-free.
- ▶ Remove feed residues immediately.
- ▶ Always keep the floor clean and dry in the working area.
- ▶ Connecting cables must be installed in such a way that they cannot cause tripping hazards or can be damaged.

! WARNING**Hazard from handling of feed components**

- ▶ When handling different feeds, pay attention to suitable personal protective equipment.
- ▶ The type of personal protective equipment is dependent on the feed being handled.

! WARNING**Hazard from fire due to dried feed components**

- ▶ Remove feed residues at regular intervals.
- ▶ Keep suitable fire extinguishers ready for use at the system.
- ▶ Do not smoke at the system and no naked flames.

! CAUTION**Hazard from moulds in the feed****Hazard from contamination with toxic plant residues**

- ▶ Clean belt at regular intervals.
- ▶ Dispose of feed residues correctly.
- ▶ Avoid dust turbulence.

! CAUTION**Risk of injury for animals from damaged belt****Risk of injury for animals from damaged wire of the winch**

- ▶ Check the wire of the winch for damage at regular intervals.
- ▶ Repair or replacement damaged belt.

! CAUTION**Hazard from silage wastewater**

- ▶ Dispose of silage wastewater correctly.

2.4.4 Hazards during transport

! CAUTION**Risk of injury during transport, assembly and disassembly from falling system components**

- ▶ Only qualified, trained and inducted personnel must carry out transport.
- ▶ Assign a competent and reliable banksman for lifting processes/loading processes.
- ▶ Use suitable transport vehicles with sufficient load capacity.
- ▶ Use suitable and sufficiently dimensioned lifting devices.
- ▶ Note the requirements for load securing.
- ▶ Note the weight data of the system components.
- ▶ No persons must be present under suspended loads.
- ▶ Take care with the centre of gravity and the inherent weight of the system components.
- ▶ Secure loose components against falling or falling over.

- ▶ Ensure a uniform load distribution.
- ▶ Wear the prescribed personal protective equipment
 - Safety shoes
 - Protective gloves
 - Safety helmet for overhead works

2.5 General protective measures

When working on the Feedstar, care must be taken that no one is endangered. This is particularly true if several persons are present near the system.

Safety devices, protective devices and protection devices must be used and maintained. Abusing them, independent removal and damage is prohibited.

Children must be denied access to the system at all times. In the event of failure to comply, Eder GmbH cannot be held liable.

The measures taken against unauthorised start-up and unauthorised running of the system must not be bypassed.

Making repairs during running operation, as well as cleaning running parts is prohibited.

The Feedstar essentially complies with the following accident prevention requirements.

General requirements	DGUV V1 (former BGV A1 or VBG 1)
Electrical machines	DGUV V3 (former BGV A3 or VBG 4)

2.6 Personal protective equipment

During operation, maintenance, setting up or dealing with faults, personal protective equipment must be used, including for example

- Eye protection
- Hand protection
- Foot protection

2.7 Obligations of the operator

The operator of the system must ensure that

- the commissioning and operation of the machine is performed exclusively by trained personnel.
- the cleaning is performed by trained specialist personnel.
- this operating manual is always available. It is part of the product.
- the operating manual and in particular the safety information have been read and understood by the personnel tasked with work before operation, maintenance and repair.
- the permissible operating conditions are complied with.
- in the case of replacement only original parts, parts approved by the manufacturer or parts with corresponding specifications are used. Other parts must only be installed following agreement with the manufacturer.
- the machine is only operated in the fault-free, operation-safe state. The technical condition must meet country-specific statutory requirements and regulations at all times.
- the system is only used according to the intended use.
- all safety provisions are complied with.
- all maintenance tasks are performed on time and properly.
- all maintenance tasks are performed exclusively by trained personnel.
- all maintenance work is performed exclusively by corresponding specialist personnel.

2.8 Training of the personnel

Before commissioning, the personnel must be fully trained regarding:

- the operation of the system
- the execution of proper maintenance

The operator must ensure that the training is repeated at reasonable intervals.

2.9 Protection devices / EMERGENCY STOP button

Protective devices are used to protect you against injuries in hazard areas.

- ▶ Only use the system with intact and functional safety devices. Before switching on, check whether all safety devices are installed.

Two EMERGENCY STOP buttons are provided on the Feedstar at the following areas:

- On the control unit
- In the area of the winch (mounting by customer)

In the case of emergency, the EMERGENCY STOP button interrupts the power supply and stops the system.

- ▶ always keep access to the EMERGENCY STOP buttons free. Do not manipulate them. Do not use for an unsuitable use, for example as a clothes hook.



Fig. 1 EMERGENCY STOP button in the area of the winch



Fig. 2 EMERGENCY STOP on the external button

3 Functional description

3.1 Use as intended

The Feedstar must be used exclusively for horizontal transport of green feed or mixing ration on smooth floors.

Intended use also includes compliance with the operating, maintenance and repair conditions specified by the manufacturer.

The system must only be used by persons who are familiar with it and are informed about the risks associated with it.

3.2 Foreseeable incorrect use

Any other use than the use described above can cause risks and damage and is not intended use. In particular this includes:

- use as a lifting device
- the overloading of the system
- Operation, maintenance and service by persons who are not trained
- the improper use with unsuitable parameters and operation in unsuitable environmental conditions (see Chapter 3.9 Technical data)
- the transport of people and animals
- the use of the system in damaged condition
- the non-compliance with the operating manual
- the non-compliance with the relevant accident prevention regulations
- the use of non-approved equipment and operating media
- an inadequate or improper maintenance and servicing
- the execution of non-approved changes
- the use of unsuitable replacement and wear parts
- operation without safety devices
- the manipulation of protective devices

The manufacturer is not liable for this damage; the risk for this is solely borne by the user.

3.3 Retrofitted components

In the case of components installed retrospectively, unless they are supplied and/or installed by Eder GmbH, the operating permit will expire.

With components and retrofits supplied by Eder GmbH the operator must carry out a corresponding assessment of the risks.

Independent changes to the machine exclude liability of the manufacturer for resulting damage.

3.4 Design of the Feedstar Lite33

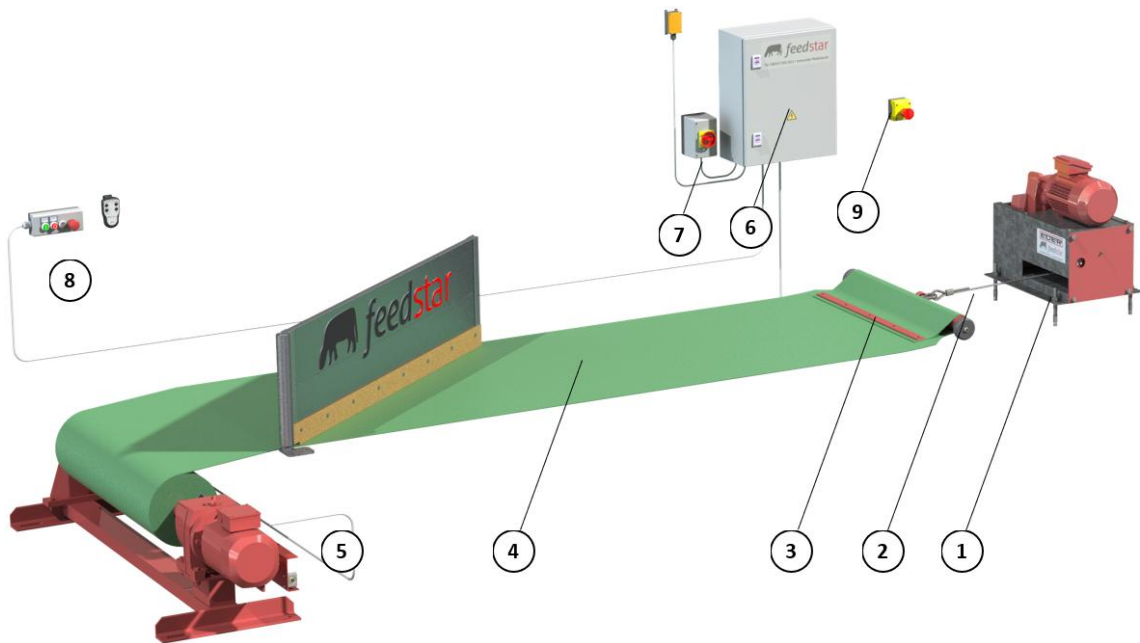

Fig. 3 Feedstar, schematic overall view

Pos.	Description	Pos.	Description
1	Winch with motor	2	Wire
3	Pull bar	4	Feed belt
5	Back roll device	6	Control box
7	Main switch	8	External button
9	Emergency stop		

3.5 Optional additional components

3.5.1 Lateral guide rollers on the pull bar

Additional guide rollers on the pull bar for extra-long or wide systems. In the area of the winch, these hold the pull bar in the U-shell. The rollers must never be adjusted too tight:

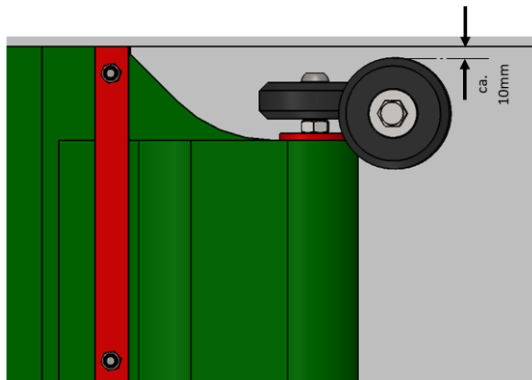

Fig. 4 Lateral guide rollers on the pull bar (optional)

3.5.2 Back roll device with deflection pulley

The back roll device can optionally be equipped with a deflection pulley. This allows the feed to be ejected behind the back roll device.

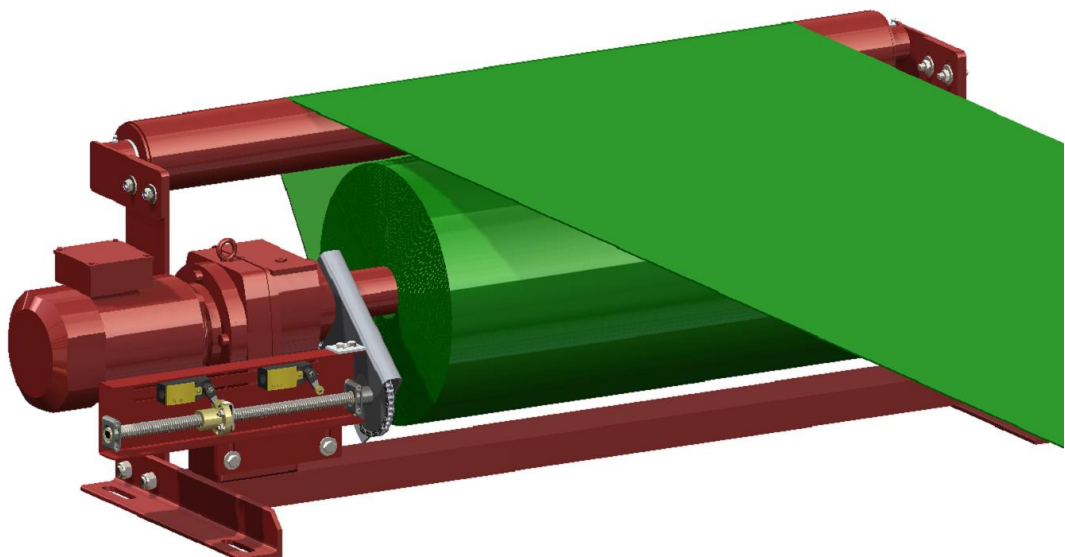

Fig. 5 Back roll device with deflection pulley (optional)

3.5.3 Steel cover with under beam

Steel cover for covering the shaft of the back roll device.

Maximum load approx. 5 t. Size variable. Measurements see assembly drawing.

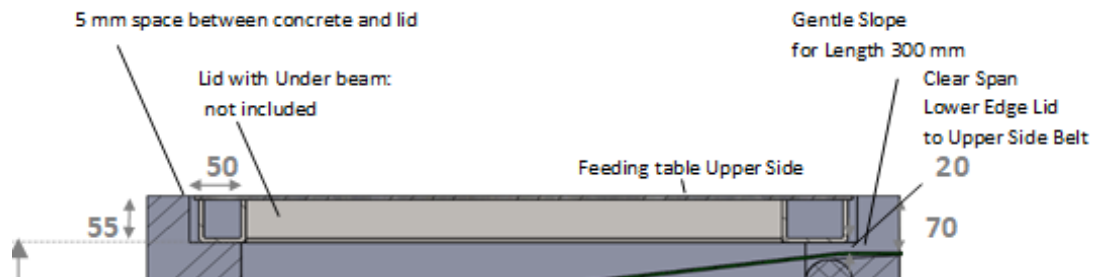
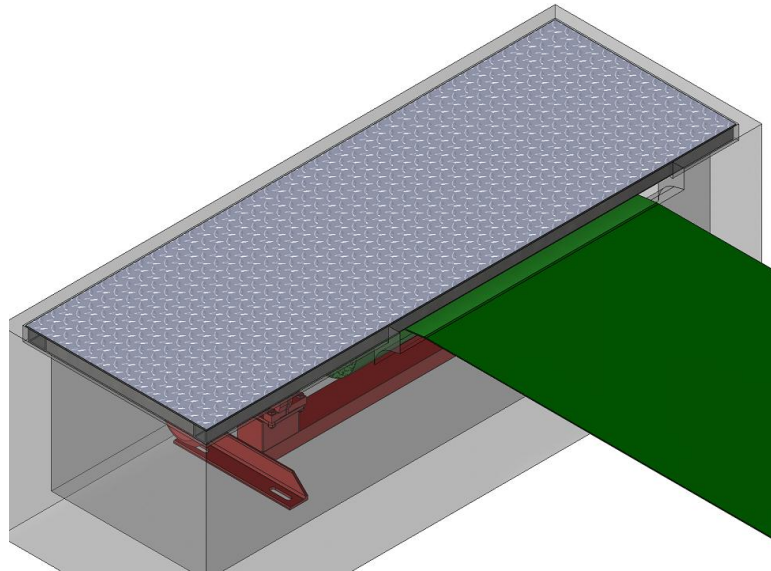

Fig. 6 Steel cover with under beam (optional)

3.5.4 Residual feed flap manual

The residual feed flap allows lateral pushing of the residual feed.

Suggestions Light flap opening for belt widths:

Bandwidth	Minimum dimension (approx. 45°)	optimal 1	optimal 2	maximum dimension (approx. 30°)
0,70m	1,03m	1,20m		1,44m
0,80m	1,17m	1,50m		1,64m
0,90m	1,31m	1,50m		1,84m
1,00m	1,45m	1,50m	2,00m	2,04m
1,20m	1,74m	2,00m		2,44m
1,40m	2,02m	2,00m	2,60m	2,84m
1,60m	2,30m	2,60m		3,24m
1,80m	2,59m	2,60m	3,30m	3,64m
2,00m	2,87m	3,30m		4,04m

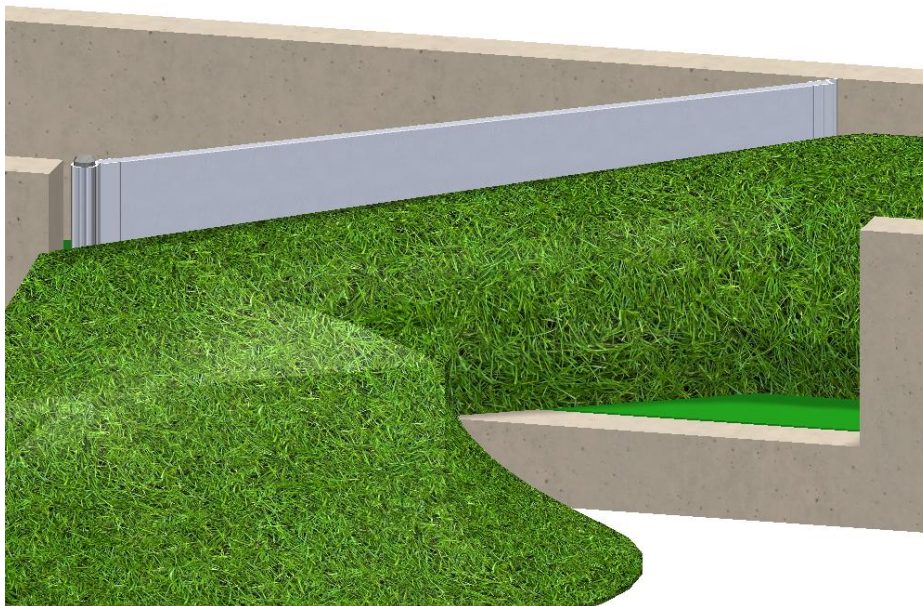

Fig. 7 Residual feed flap manual (optional)

3.5.5 Shield pull bar

The shield protects the tie beam from chuck pushed forward. Not possible in combination with the installation of the end board.

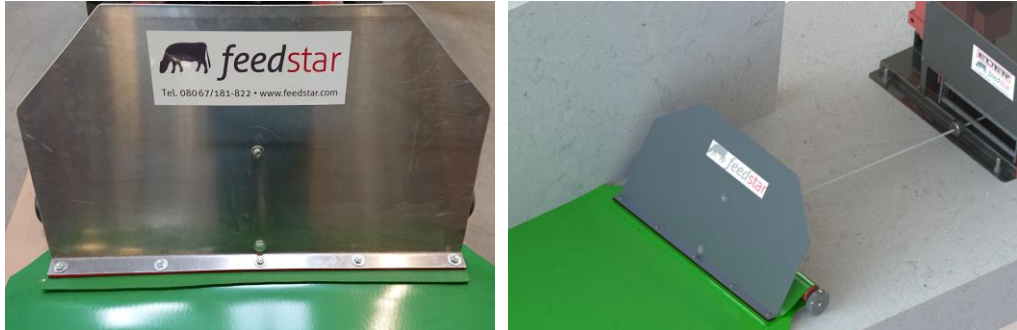

Fig. 8 Shield pull bar

3.5.6 Limit switch on back-roll-device

The back-roll-device is equipped with a limit switch.

This limit switch device contains two limit switches.

One limit switch is for the end position of the retracted belt on the winch.

The second limit switch is for the position of the belt after retraction on the roll-back device or on the residual feed flap.

HINWEIS

For automatic retraction, the back-roll-device must be protected and a warning sign 'No unauthorised persons' must be affixed.

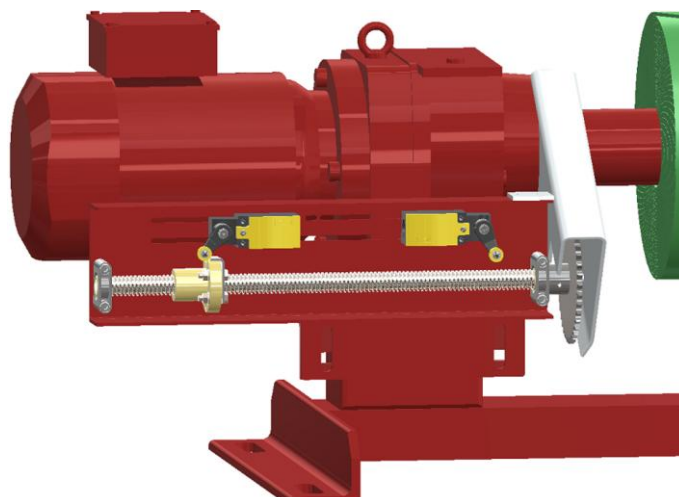

Fig. 9 Limit switch on back-roll-device

3.5.7 Module wall system

The modular wall system can be optionally used for the second elevated bar wall for one-sided feeding. It consists of modular walls 198.8 x 75cm, H-stainless steel supports and U-rails.

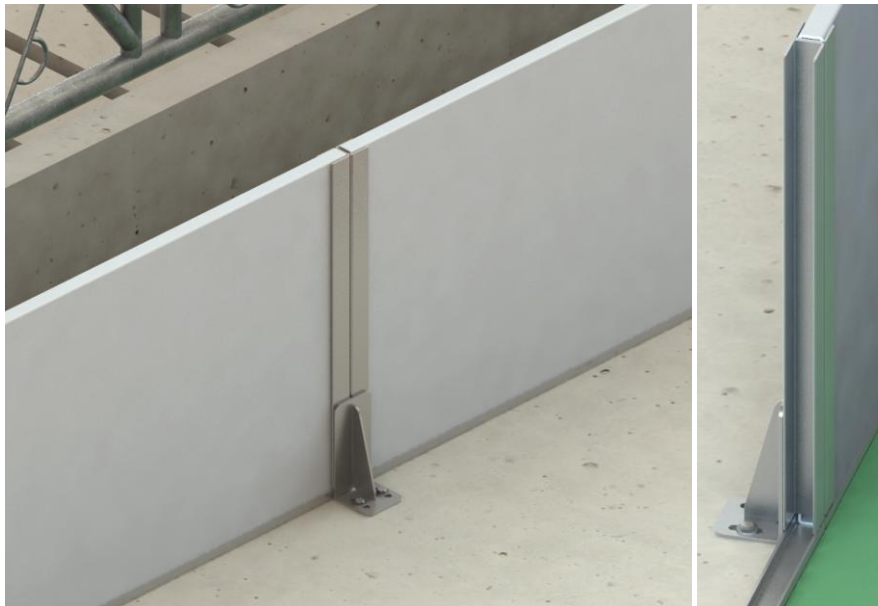
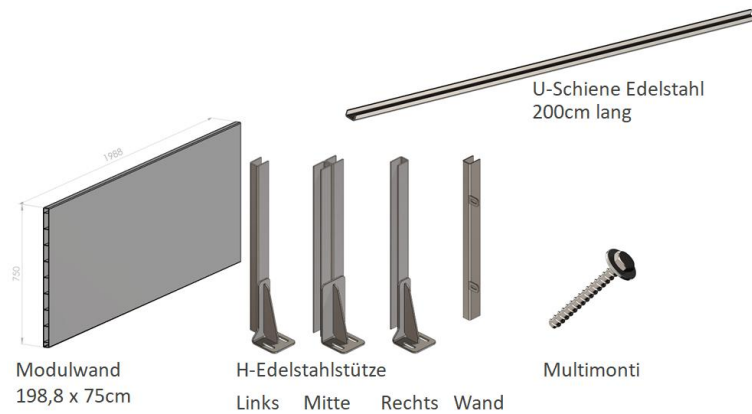

Fig. 10 Modular wall system installed

3.5.8 Precast concrete elements

The following precast concrete parts are available:

Concrete chute; Concrete cover; Feed hopper; Residual feed discharge; Catch residual feed; U-tray.

The dimensions of the precast concrete parts are manufactured individually and in consultation with the client. Adjustments to the existing terrain and slopes must be made on site by the customer.

The supplied precast concrete elements must be installed in accordance with the specifications of the "Fachvereinigung Deutscher Betonbauer" and the currently applicable

accident prevention regulations. (Maximum permissible dimensional deviations according to Table 1 of DIN 18202).

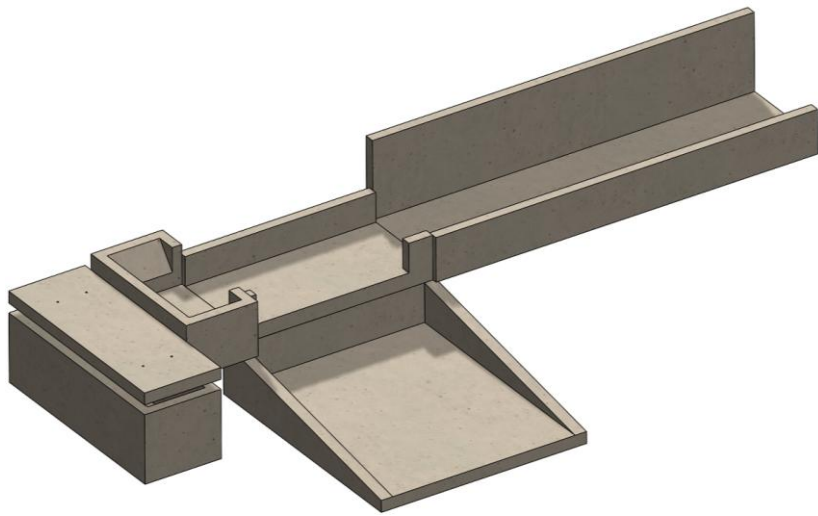

Fig. 11 Precast concrete elements

3.5.9 End board (on-site)

The end board protects the area in front of the winch and the cable pull-in with the limit switch from chucks. Not possible in conjunction with the installation shield tension beam

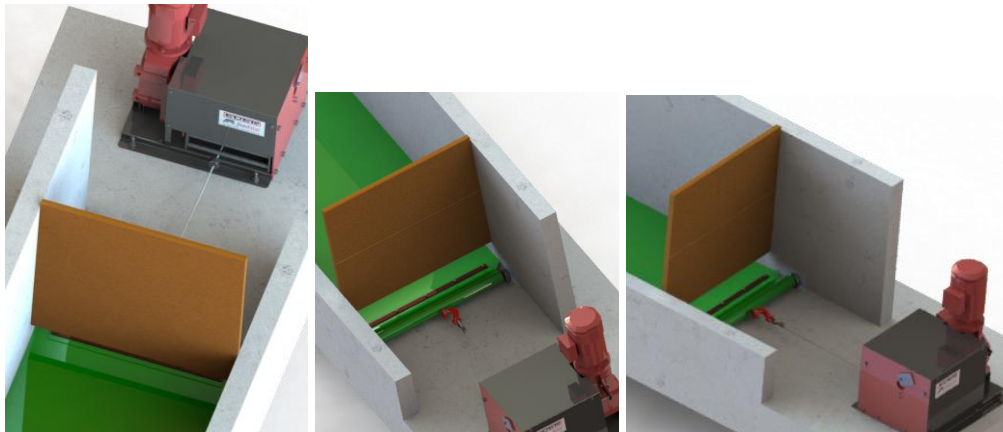

Fig. 12 End board for winch (on-site)

3.6 Control unit

The system is controlled with operating elements via a mobile control unit.

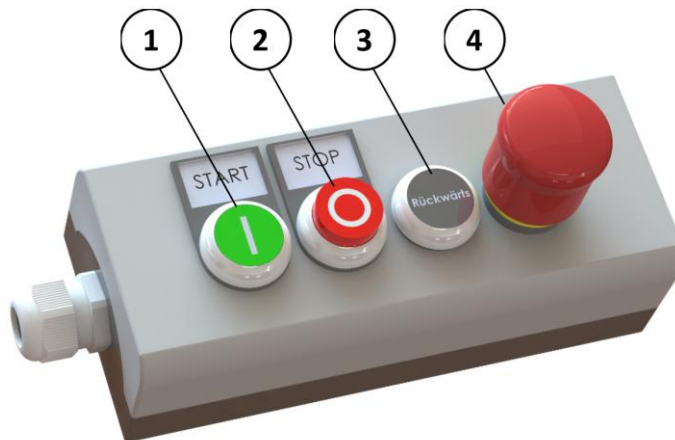

Fig. 13 External button



Fig. 14 Remote control (optional)

Pos.	Description and function
1	Press button to switch the belt on. The belt runs into the stall (forward).
2	Pressing the button switches the belt off
3	Pressing the button (keep it pressed!) makes the belt run out of the stall (backwards).
4	EMERGENCY STOP button
5	Pressing the button increases the belt speed (only with frequency converter)
6	Pressing the button decreases the belt speed (only with frequency converter)

3.7 Control box

Control box and main disconnect switch.

The main disconnect switch should be installed near the control box.

(Dimensions approx. w=400 h=500 d=210 mm)



Fig. 15 Control box and main disconnect switch

3.8 Type plate

Attached to the winch:



Fig. 16 Type plate

3.9 Technical specifications

Type off winch	Lite33
Loading with material max. [t]	3
Usable wires (synthetic), Diameter [mm]	8
Belt speed [m/min]	6
Motor power [kW]	2,1

All data are guideline values and must be determined individually.

4 Mounting

During the mounting of the system, the safety information in Chapter 2.3 and warning signs and symbols referred to in Chapter 2.4 must be complied with – this avoids potentially fatal injuries, machine damage and other property damage.

4.1 Mounting of the winch

The winch is mounted horizontally at the end of the belt at the height of the feed table. The winch is secured with 4 M16x148 bolt anchors.

- ▶ The centre of the feed table is marked on the winch. This is the only way to ensure optimum belt feed.
- ▶ The length of the pull rope must be selected so that at least 3 rope layers remain on the drum winch when the belt is completely wound up.
- ▶ The rope must be wound up neatly in each position in sequence, as pre-assembled.

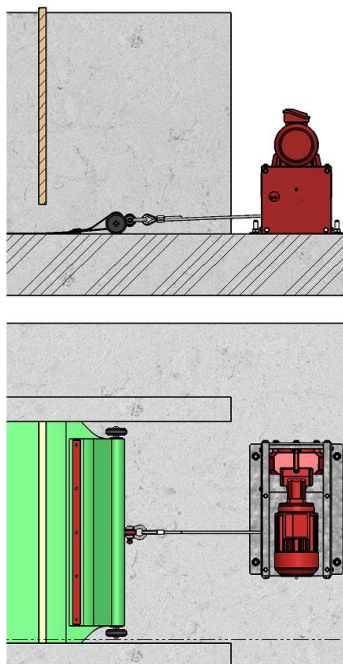

Fig. 17 Mounting winch Lite33

WARNING



Risk of entanglement in the winch area

- ▶ The protective cover supplied must be fitted.
- ▶ The system must not be operated without the protective cover.

4.2 Mounting the back roll device:

- ▶ The back roll device is mounted horizontally and angularly aligned with the belt.
- ▶ The back roll device is mounted anchored in the floor as standard. The dimensions of the recess are determined by the width and length of the feed belt. For this see the enclosed assembly drawing with the project-specific dimensions. The shaft depth may differ for inclines.
- ▶ The back roll device is fixed in the shaft with 4 bolt anchors M16x148 and large washers. Remove the roll-off protection (cable tie) on the motor.
- ▶ Shaft height on slope:

The shaft depth on slopes must be corrected according to the sketch. Center of the shaft Escape from the slope = Height BRD +50mm
- ▶ Pull the belt approx. 3-4m into the U-bowl and set the re-winder at exactly 90° to the feed table.

The hanging transition (the belt is taut on one side and sagging on the other) shows whether the alignment is correct.
- ▶ The correct angle can be readjusted by means of the slotted holes on the re-winder.

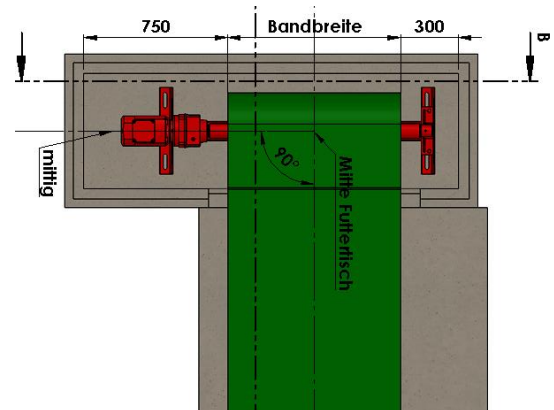

Fig. 18 Dimensions back roll device

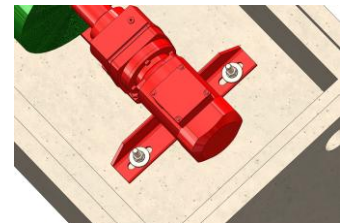

Fig. 19 Fastening back roll device

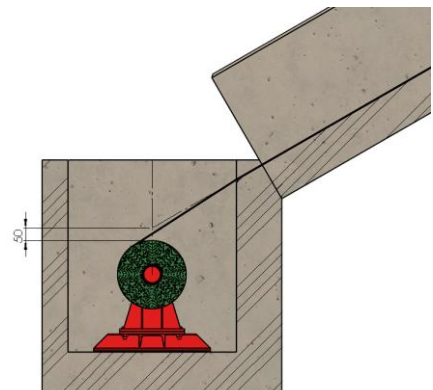

Fig. 20 Belt infeed back-roll-device

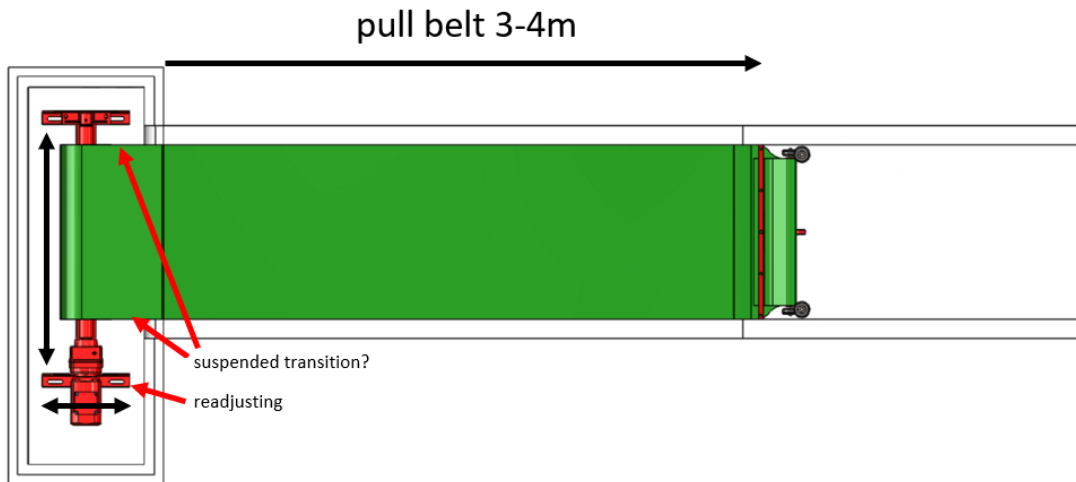

Fig. 21 Mounting back roll device

The back-roll-device has two limit switches

- (1) This limit switch is for the end position of the retracted belt on the winch with the motor on the right.
- (2) This limit switch is for the position of the belt after retraction on the retraction device or on the residual feed flap (with the motor on the right)

With the motor on the left, the functions of the limit switches are reversed on the retraction device. Move the belt to the end stop position, reposition the chain and move the limit switch so that the metal activates the limit switch when the belt moves to the stop point.

The tolerance is approx. 5-10 cm for retraction and approx. 50 cm for retraction.

NOTE

For automatic retraction, the retraction device must be protected and a warning sign 'No unauthorised persons' must be affixed.

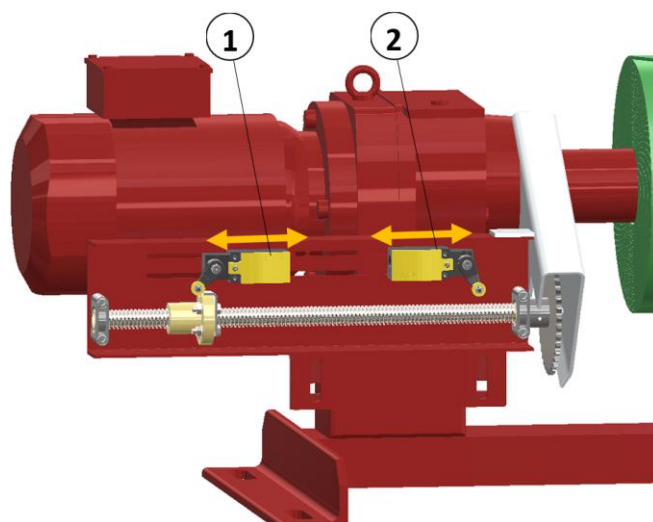

Fig. 22 Limit switch back-roll-device

NOTE

Due to belt elongation, it may be necessary to readjust the limit switches. Regular checks prevent damage to the winch.

! WARNING
Risk of tripping and entanglement in the area of the back roll device

The recessed back roll device must be secured with a non-slip plate suitable for walking on.

The system must not be operated without this plate.

4.3 Final mounting:

- ▶ Pull out the wire and hook into the pull bar.

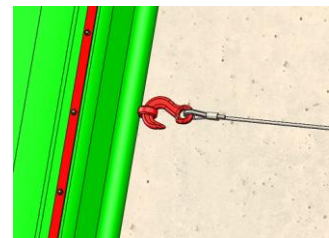

Fig. 23 Mounting wire

An end board:

- ▶ An end board (provided by the customer) prevents soiling of the area between the winch and the belt. To allow the tension beam to pass underneath, we recommend a distance of approx. 10 - 12 cm without guide rollers and 13 - 15 cm for a tension beam with guide rollers. (See point 3.5.12).

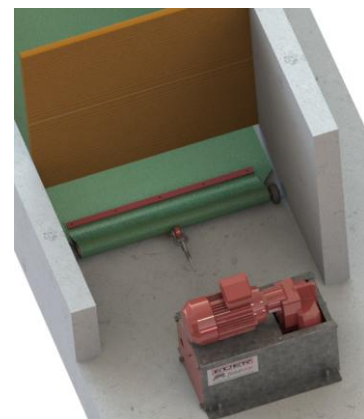
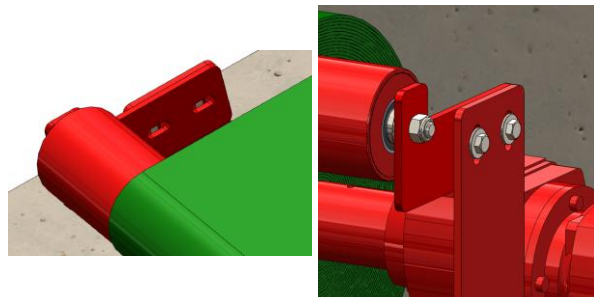
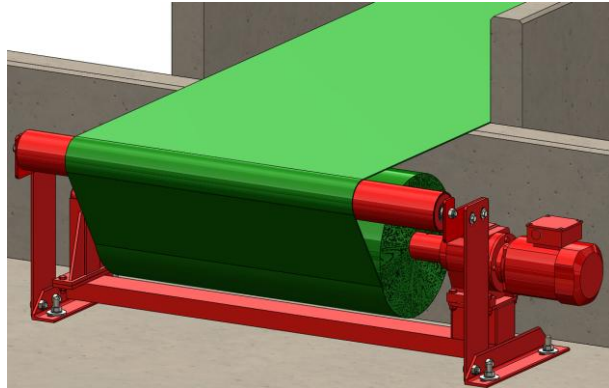

Fig. 24 End board

4.4 Mounting optional additional components

4.4.1 Back roll device with deflection

- ▶ The back roll device is fixed to the floor with 4 bolt anchors and large washers.
- ▶ The angle of the back roll device can be adjusted correctly using the elongated holes.
- ▶ The deflection pulley is also set up exactly at the correct height and level using elongated holes.



The belt roller, deflection and feed table must be as exactly parallel to one another or perpendicular as possible

An example showing how the deflection pulley can be enclosed by the customer

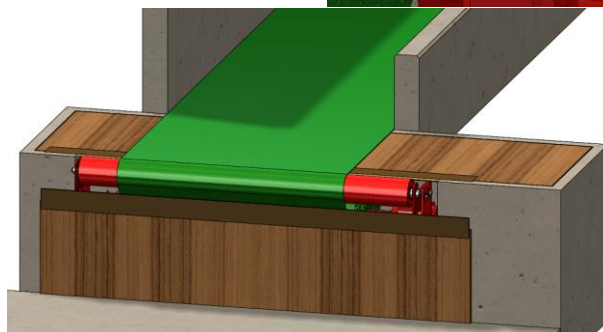

Fig. 25 Mounting BRD with deflection

4.4.2 Residual feed flap manual

The residual feed flap is composed of a vertical pipe and an aluminium flap.

The height of the plate is 400mm, the length varies according to the belt width.

- ▶ The vertical pipe is mounted flush with the inner edge with 2 bolt anchors in such a way that the distance of the flap to the fold is approximately 5-7mm. The flap is only placed on.

Image example for BRD right (left mirror image)

direction winch

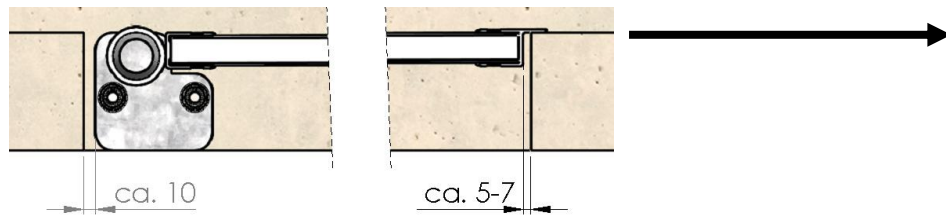

Fig. 26 Mounting the residual feed flap

4.4.3 Shield pull bar

The aluminium shield is screwed to the fixing bars of the tension beam with M8 x 30 countersunk screws.

The spacer prevents the sign from tilting as it rests on the tension beam. The height is approx. 400mm, the width corresponds to the width of the fixing bars. (strip width minus 150mm)

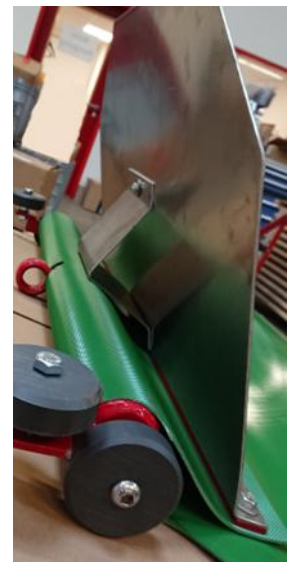



Fig. 27 Mounting shield pull bar

4.4.4 Rubber lip

The rubber lip has the following dimensions: 200cm x 8.0cm x 0.8cm.

No fastening material is supplied, because the rubber can be attached in a wide variety of locations. For this the lip must also be cut to shape. Here a few examples:

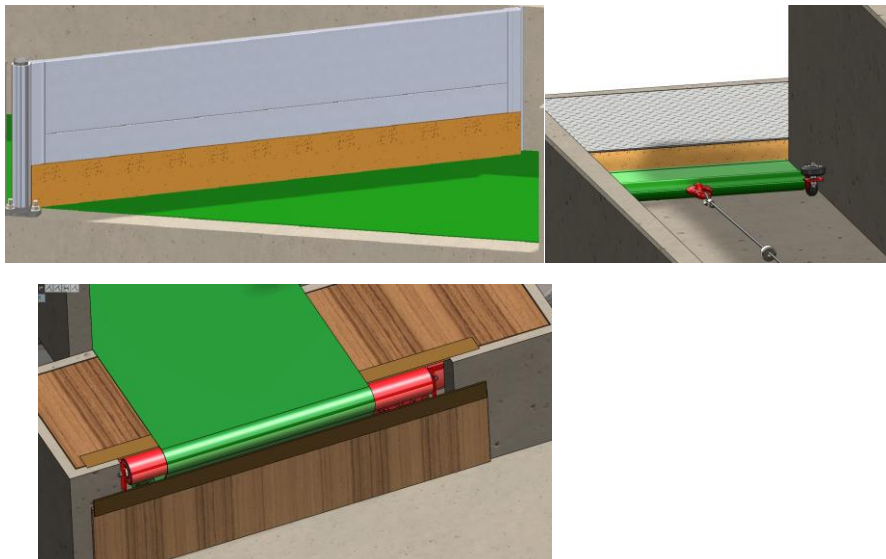

Fig. 28 Mounting rubber lip

4.4.5 Module wall

with the following dimensions, the supports are fixed to the floor with Multi Monti.

The distance from the concrete wall to the outer edge of the prop corresponds to the strip width.

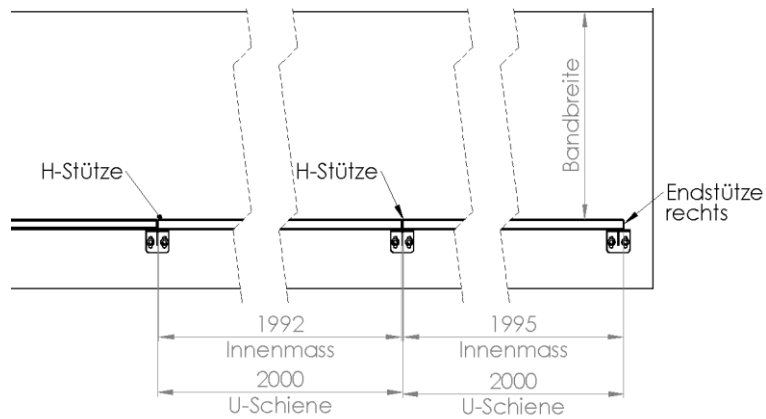

Fig. 29 Assembly of H-props and end supports

Then place the U-rail on the floor between the supports and insert the modular wall from above.

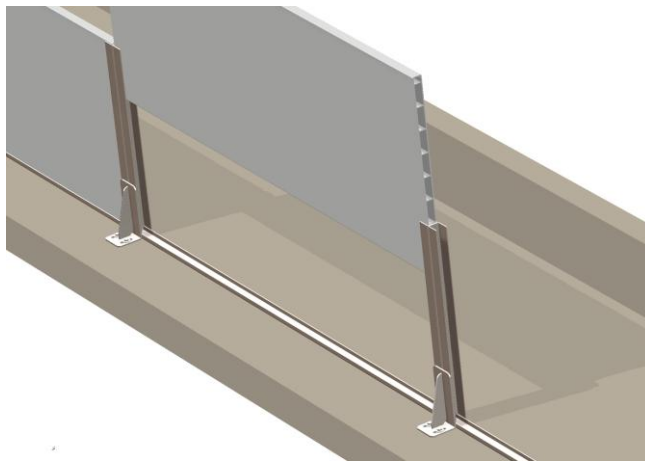

Fig. 30 Inserting the module wall

4.5 Electrical installation

- ▶ The electrical connection must only be carried out by a specialist, who must ensure, for example, that the winch runs in the correct direction of rotation! The contactors, on/off switches and electrical installation diagrams are supplied.
- ▶ The control system must be protected on site with a type C or K circuit breaker.
- ▶ The functions of the shut-off device (limit switch) must be checked before commissioning!
- ▶ The check must be carried out under load and at low speed to prevent the gearbox from running on.
- ▶ When mounting the control box on a wall, observe the statutory accident prevention regulations.
- ▶ When mounting the switch box on a wall, observe the load-bearing capacity of the wall. If the load-bearing capacity of the wall is insufficient, use another structurally stable and secure construction.
- ▶ Lay the cable so that it does not create any trip hazards.
- ▶ Damaged cables (breaks, cracks) must be replaced immediately to prevent personal injury.

The system is now ready for operation.

4.5.1 Cable cross-sections in relation to components

The cable cross-sections must be calculated in each individual case by the on-site electrician. The following are non-binding suggestions from EDER GmbH.

Fuse protection with LS switch type C or K.

	Contactor control	Frequency converter:
- Main disconnect switch	5 x 2,5mm ²	characteristic "C" or "K"
- Motor cable winch Lite33:	4 x 2,5mm ² (YSLY-JZ)	4 x 2,5mm ² (YSLYCY-JZ)
		<u>shielded</u>
- Emergency stop circuit	3 x 1,5mm ² (YSLY-JZ)	
- Motor cable for back-roll-device:		
- Back-roll-device Lite33:	4 x 2,5mm ² (YSLY-JZ)	4 x 2,5mm ² (YSLYCY-JZ)
		<u>shielded</u>
- Control cable for push button:	9 x 1,5mm ² (YSLY-JZ)	
- Limit switch BRD:	3 x 1,5mm ²	

All electrically conductive parts and all metal components must be connected to the equipotential bonding system!

4.5.2 Connecting the radio remote control

The radio remote control can be retrofitted at any time.

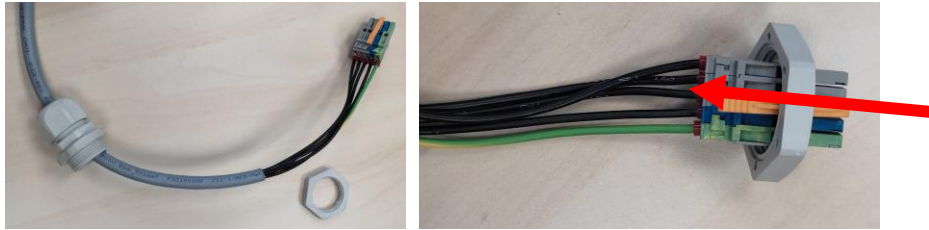

Fig. 31 Receiver connection cable with strain relief

Guide the connection cable with strain relief through the base plate, then slide the counter nut over the plug.

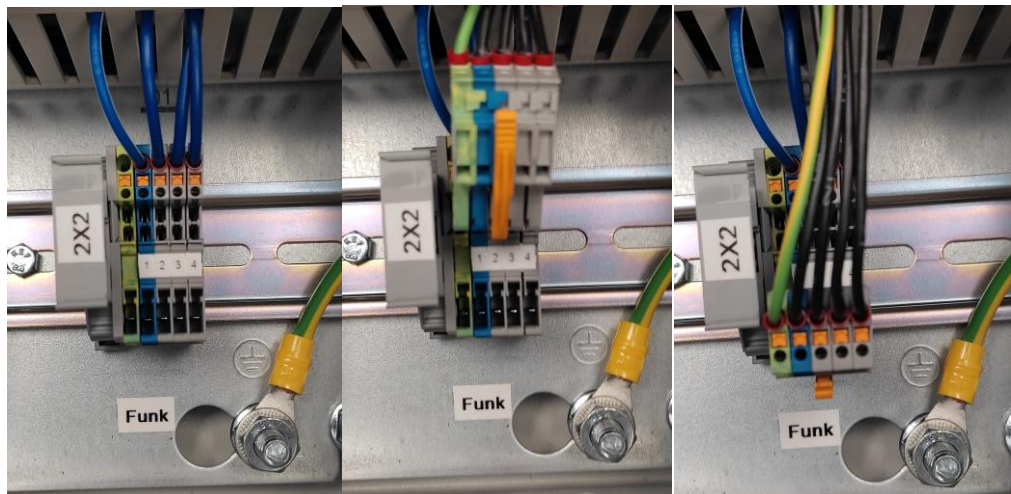

Fig. 32 Plug connection receiver to terminal 2X2

Then simply plug the connector into terminal 2X2.

5 Operation

During the operation of the system, the safety information in Chapter 2.3 and warning signs and symbols referred to in Chapter 2.4 must be complied with – this avoids potentially fatal injuries, machine damage and other property damage.

- ▶ Before starting work, familiarise yourself with the system. During the work it is too late!
- ▶ Check whether the wire, feed belt and electrical components (especially end switch off and deadman circuit) are in proper condition before each operation. The check must be performed during loading and low speed in order to prevent the transmission running on.
- ▶ Pay attention to the belt tension.
- ▶ If the pull bar comes too close to the winch, the limit switch must be readjusted.
- ▶ Check the protective devices for functional performance before each operation.
- ▶ If you notice safety relevant changes, do not place the system in operation! First place all the protective devices in a proper condition.
- ▶ Make sure that no obstacles can enter the tension belt and the tensile force increases until the wire or the belt breaks.
- ▶ Switch the system on at the main switch (see Fig. 15).
- ▶ From a filling quantity of approximately 60% the belt must be run through to the end stop because it's possible that the winch is unable to start due to overloading.

The system is now in operation.

5.1 Filling the Feedstar

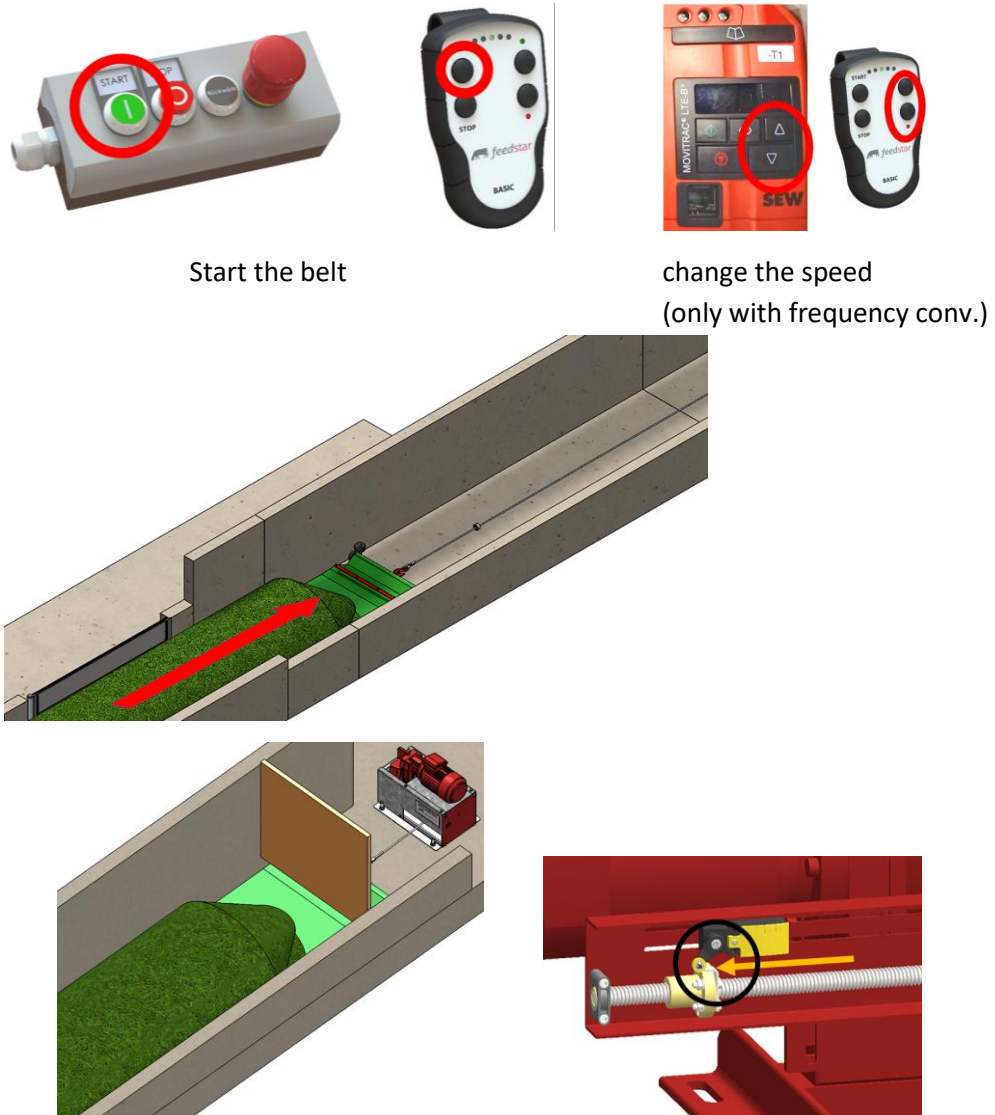

Start the belt

change the speed
(only with frequency conv.)

Fig. 33 Filling the feedstar

- ▶ Run the feed belt into the stall (see 3.6 Operating unit).
- ▶ Slowly tip feed from a storage vessel or filling device onto the belt.
- ▶ Regulate the filling quantity with your filling device.

Without frequency converter:	The system enters at a constant speed.
With frequency converter:	The system increases the speed to the last speed driven. The speed can be changed on the frequency converter or by radio.
- ▶ The belt must be filled evenly and allow it to run through continuously until the end switch from 2/3 full. Avoid stopping and restarting with filled belt.
 - The system has an end switch. Once the belt has fully entered into the shed, the system automatically stops. See example image RRV motor on the right (with the motor on the left, the actual limit switch for switching off is on the winch)
- ▶ A final board (provided by customer) prevents contamination of the area between the winch and belt. To ensure that the pull bar passes under it, we recommend a distance

of approximately 10 -12cm without guide rollers and 13 – 15cm for a pull bar with guide rollers.

- ▶ The filling process is complete.

5.2 Emptying Feedstar

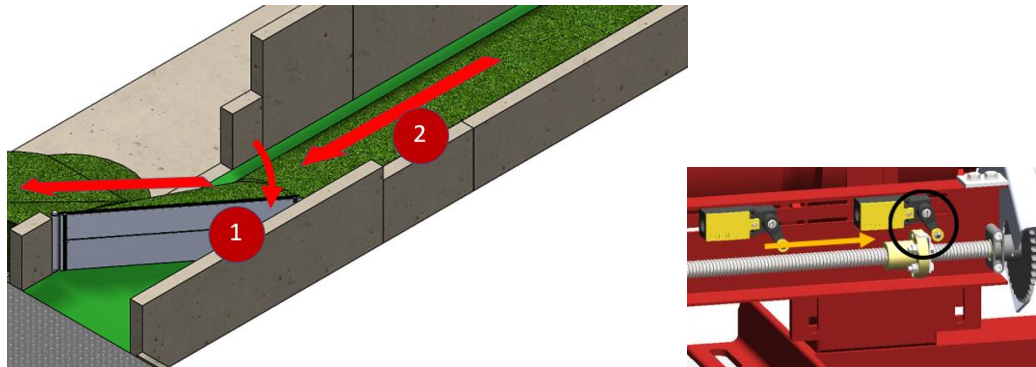
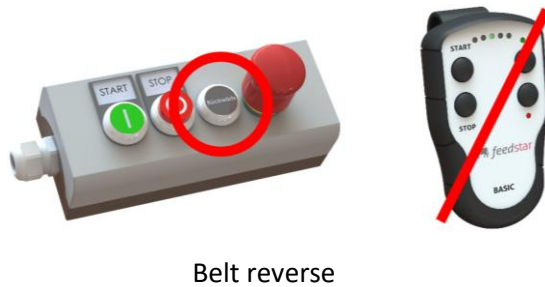

Fig. 34 Emptying Feedstar

- ▶ (1) Open the residual feed flap (optional, see Fig. 7) in order to collect the remaining feed in the floor trough.
- ▶ (2) Allow the feed belt to run out of the barn. Avoid stopping and restarting.
- ▶ The back-roll-devis is equipped with an end switch. This automatically stops the system as soon as the belt has run out of the barn. Example image of back-roll-devis with motor on the right. (for back-roll-devises with motor on the left, the left limit switch is for switching off the rollback device)
- ▶ Close the residual feed flap.

The system is ready for the next filling.

6 Faults

During the rectification of faults, the safety information in Chapter 2.3 and warning signs and symbols referred to in Chapter 2.4 must be complied with – this avoids potentially fatal injuries, machine damage and other property damage.

Phone number Hotline (also on weekend – only German speaking): 0175 2602376

Fault	Cause	Rectification
Feed belt judders during running into the shed	There is an obstacle in the track	Remove the obstacle.
Belt does not move	The main switch in position "O" Emergency stop pressed There is an obstacle in the track. The wire is not connected to the pull bar or is torn The batteries of the remote control are too weak Motor or cables are defective	Switch the system on. Check the emergency-stop switch Remove the obstacle. Connect the wire to the pull bar if it is still long enough. Otherwise replace the wire. Change the batteries of the remote control. Switch off the system, check the lines for interruptions (pitted?) and call the Eder GmbH service hotline.
Drive makes unusual noises	Motor or chain drive are defective	Switch the system off and call the Service-Hotline of Eder GmbH.
Winch runs on	Belt not loaded Brake linings oiled or worn out	Belt loaded Degrease brake linings, retention spring or

7 Maintenance and inspection

7.1 General Information

During the maintenance and inspection of the system, the safety information in Chapter 2.3 and warning signs and symbols referred to in Chapter 2.4 must be complied with – this avoids potentially fatal injuries, machine damage and other property damage.

Cleaning and maintenance work must only be performed by authorised personnel - the operating instructions must be complied with exactly.

Replacement parts must meet at least the technical requirements specified by the device manufacturer.

Only carry out maintenance, cleaning and repair work with stationary drives and main switch switched off.

All work on the electrical equipment of the machine must only be performed by trained electrical specialists.

NOTE

After the end of maintenance or repair, make sure that no tools, cleaning articles or other parts are present in the system.

NOTE

In your own interest, please note that necessary repairs or maintenance which extend beyond this technical documentation during the warranty period can only be carried out by Eder GmbH themselves.

7.2 Maintenance plan

Activity	weekly	quarterly	if required
Check the distance between the pull bar and the winch . If necessary, readjust the limit switch on the RRV.	X		
Check the rope and feed belt for wear (especially the rope inlet when the rope is retracted and the rubber lip on the inlet feed table).	X		
Clean the system.		X	
Lubricate the drives. Winch: 1 grease nipple on the side of the winch Back-roll-device: 1 grease nipple		X	
Limit switch at the back-roll-device: Check the spindle for contamination.			X

7.3 Gear oil

- Winch Lite33 flat gearbox see image 3,55ltr.
- Back-roll-device Lite33 gearbox oil CLP VG220
I check screw countercheck: 0,50ltr.
see type plate

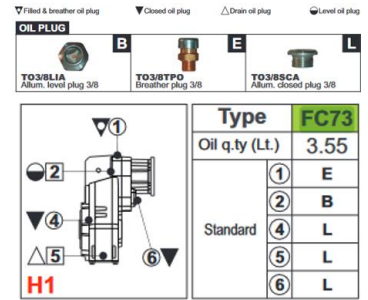

7.4 Exploded view

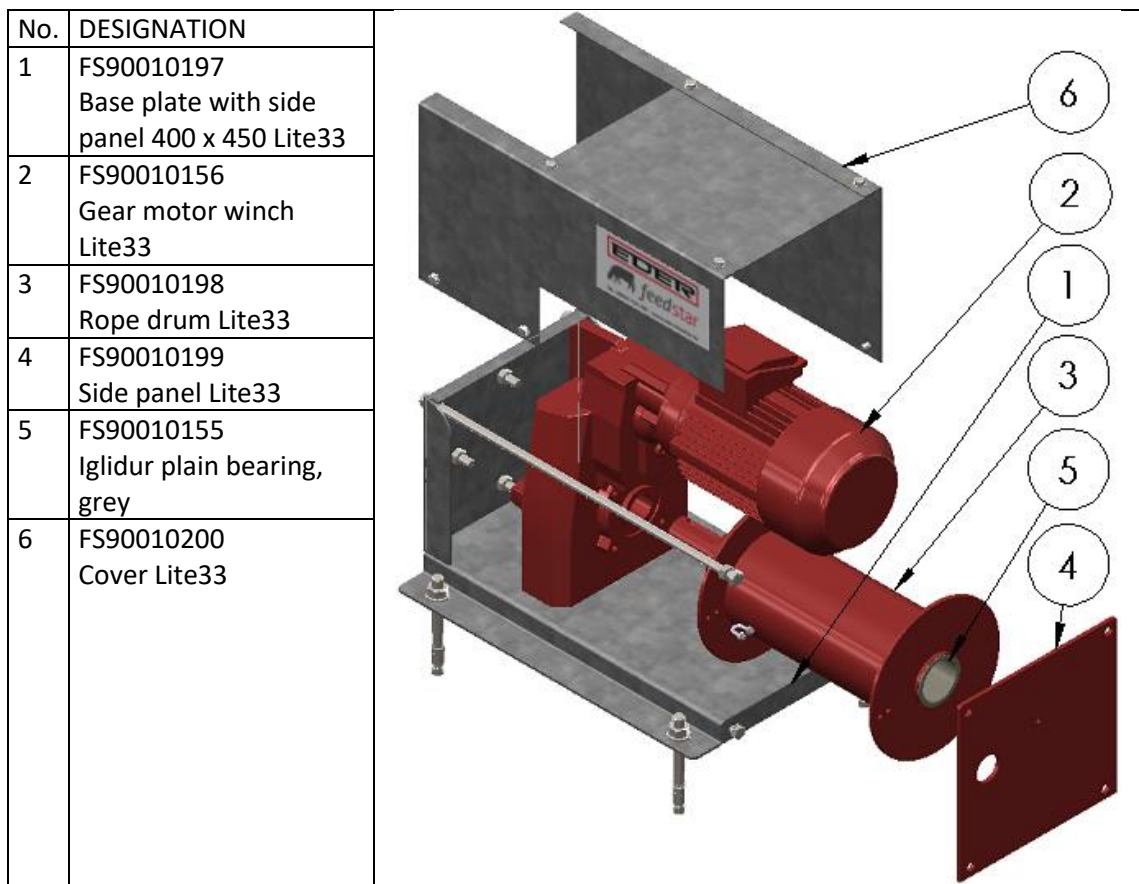

7.5 Repairs

NOTE

Required repairs must only be performed by authorised and appropriately trained specialist personnel. The accident prevention regulations must be complied with.

8 Removal and decommissioning

During the removal and decommissioning of the system, the safety information in Chapter 2.3 and warning signs and symbols referred to in Chapter 2.4 must be complied with – this avoids potentially fatal injuries, machine damage and other property damage.

The decommissioning of the system must only be performed by qualified persons in accordance with the safety information.

8.1 Decommissioning

For temporary decommissioning, the system must be switched off at the main switch.

8.2 Final decommissioning

For the final decommissioning in addition to the points mentioned above the securing of the main switch against re-switching must also be ensured.

9 Recycling and disposal

The system consists largely of valuable recyclable materials which are to be sent for recycling. Using a modular design, dismantling into its component parts is possible without problems.

Make sure that all applicable laws, standards, regulations and regional regulations are complied with during the disposal of the system.

Take the system completely out of operation.

Separate the dismantled parts according to material.

Make sure that the parts to be disposed of and if necessary, the existing accessories are sent for proper disposal.

Once the system reaches the end of its life cycle, it must be ensured that safe and proper disposal, in particular of parts or substances which are harmful to the environment, take place during its dismantling.

INFORMATION

We recommend you to engage a certified regional specialist company to dispose of your machine.

10 Declaration of Conformity (German version)

EG-Konformitätserklärung

im Sinne der EG-Maschinenrichtlinie 2006/42/EG, Anh. II 1. A

Hersteller

EDER GmbH

Moorweg 5

DE - 83104 Tuntenhausen

In der Gemeinschaft ansässige Person, die bevollmächtigt ist, die technischen Unterlagen zusammenzustellen

Geschäftsführer

EDER GmbH

Moorweg 5

DE - 83104 Tuntenhausen

Beschreibung und Identifizierung der Maschine

Produkt / Erzeugnis	Futterband
Type	Feedstar basic und vario
Seriennummer	200 bis folgende
Handelsbezeichnung	Futterband
Funktion	Aus einem Vorratsbehälter wird Grünfutter oder Mischration auf ein Futterband gekippt. Durch eine Seilwinde wird das beladene Futterband gleichmäßig in einem Futtertrog über die gesamte Länge der Fütterungszone gezogen. Die Abschaltung der Seilwinde erfolgt über einen Endschalter an der Seilwinde. Nach Beendigung der Fresszeit wird das Futterband von einem Bandrückführsystem aufgewickelt. Evtl. vorhandenes Restfutter wird von einem beweglichen Abstreifer (Gurtreinigung) in eine Auffanggrube neben dem Futterband befördert.

Es wird ausdrücklich erklärt, dass die Maschine allen einschlägigen Bestimmungen der folgenden EG-Richtlinien bzw. Verordnungen entspricht:

2006/42/EG	Richtlinie 2006/42/EG des Europäischen Parlaments und des Rates vom 17. Mai 2006 über Maschinen und zur Änderung der Richtlinie 95/16/EG (Neufassung) (1) Veröffentlicht in L 157/24 vom 09.06.2006
2014/30/EU	Richtlinie 2014/30/EU des Europäischen Parlaments und des Rates vom 26. Februar 2014 zur Harmonisierung der Rechtsvorschriften der Mitgliedstaaten über die elektromagnetische Verträglichkeit (Neufassung) Veröffentlicht in L 96/79 vom 29.03.2014

Fundstelle der angewandten harmonisierten Normen entsprechend Artikel 7 Absatz 2:

EN ISO 12100:2010-11	Sicherheit von Maschinen - Allgemeine Gestaltungsleitsätze - Risikobewertung und Risikominderung (ISO 12100:2010)
EN ISO 13857:2008	Sicherheit von Maschinen - Sicherheitsabstände gegen das Erreichen von Gefährdungsbereichen mit den oberen und unteren Gliedmaßen (ISO 13857:2008)
EN 14492-1:2006+A1:2009/AC:2010	Krane - Kraftgetriebene Winden und Hubwerke - Teil 1: Kraftgetriebene Winden
EN 60204-1:2006/AC:2010	Sicherheit von Maschinen - Elektrische Ausrüstung von Maschinen - Teil 1: Allgemeine Anforderungen
EN 620:2002+A1:2010	Stetigförderer und Systeme - Sicherheits- und EMW-Anforderungen für ortsfeste Gurtförderer für Schüttgut
EN 1037:1995+A1:2008	Sicherheit von Maschinen - Vermeidung von unerwartetem Anlauf
EN ISO 14120:2015	Sicherheit von Maschinen - Trennende Schutzeinrichtungen - Allgemeine Anforderungen an Gestaltung, Bau und Auswahl von feststehenden und beweglichen trennenden Schutzeinrichtungen (ISO 14120:2015)
EN ISO 13849-1:2015	Sicherheit von Maschinen - Sicherheitsbezogene Teile von Steuerungen - Teil 1: Allgemeine Gestaltungsleitsätze (ISO 13849-1:2015)
EN ISO 13850:2015	Sicherheit von Maschinen - Not-Halt - Gestaltungsleitsätze (ISO 13850:2015)
EN 60204-1:2006/A1:2009	Sicherheit von Maschinen - Elektrische Ausrüstung von Maschinen - Teil 1: Allgemeine Anforderungen

Tuntenhausen, 07.07.2018
Ort, Datum

EDER
GmbH • Moorweg 5
83104 Tuntenhausen
Tel. 08067/181-0 / Fax 181-792
Unterschrift
Georg Pfeilschifter
Geschäftsführer