

Operating manual

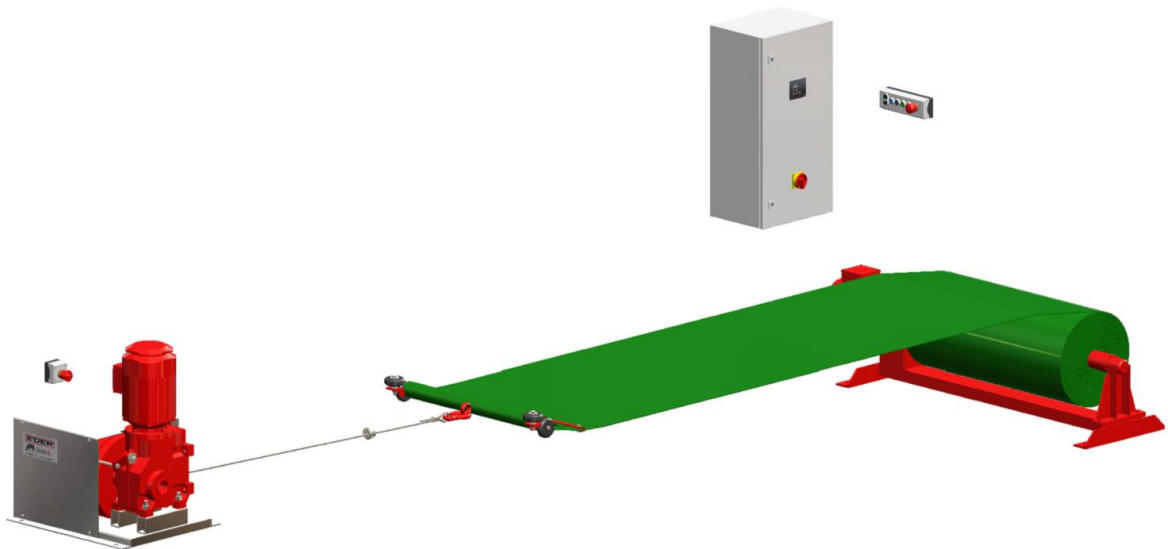

feedstar Vario

July 2020

Eder GmbH
Moorweg 5
83104 Tuntenhausen

Tel. +49 8067 181-822
Web www.eder-feedstar.de
e-mail feedstar@eder-gmbh.de

Revision				
Date	Version	Chapter	Reason	Responsible
01.07.2020	01.00	All	translation	Markus Grad - Eder GmbH

All information and drawings were up to date at the time of printing.

This operating manual was created according to our best knowledge. If you discover errors or unclear areas nevertheless, we would ask you to inform us. Furthermore we would be happy to receive your comments and suggestions.

Subject to technical changes.

WARNING RISK OF DESTRUCTION!

**Never allow the belt to run unloaded
into the end stop of the winch.**

This operating manual is the property of

Eder GmbH
Moorweg 5
83104 Tuntenhausen

Reproduction, copying and translation – even as extracts - of the operating manuals of Eder GmbH is only permitted with our prior consent and with reference to the source.

Tuntenhausen, 04th June 2020

Table of Contents

1	Notes regarding the documentation	6
1.1	Purpose.....	6
1.2	Liability	6
1.3	Target group	7
1.4	Display of information	7
1.5	Setup and structure of the safety and warning information	7
1.6	Storage of the documents	8
1.7	Validity of the manual	8
2	Safety	9
2.1	Classification of the action-related warning information	9
2.2	Machine stickers, warning, prohibition and mandatory signs	10
2.3	General safety information	11
2.4	Warning information	12
2.4.1	Complete system	12
2.4.2	Hazards in the area of the Feedstar	15
2.4.3	Hazards for people and animals from feed and auxiliary substances.....	16
2.4.4	Hazards during transport	17
2.5	General protective measures	18
2.6	Personal protective equipment.....	18
2.7	Obligations of the operator.....	19
2.8	Training of the personnel	19
2.9	Protection devices / EMERGENCY STOP button.....	20
3	Functional description	21
3.1	Use as intended	21
3.2	Foreseeable incorrect use	21
3.3	Retrofitted components.....	21
3.4	Design of the Feedstar Vario	22
3.5	Optional additional components	23
3.5.1	Lateral guide rollers on the pull bar	23
3.5.2	Back roll device with deflection pulley.....	23
3.5.3	Lower back roll device with deflection pulley.....	24
3.5.4	Back roll device narrow with chain drive	24
3.5.5	Steel cover with under beam	25
3.5.6	Residual feed flap manual	26
3.5.7	End switch for back roll device.....	26

3.5.8	Safety switch for end switch of the back roll device.....	27
3.6	Control unit	28
3.7	Control cabinet.....	29
3.8	Type plate.....	29
3.9	Technical data	29
4	Mounting	30
4.1	Mounting of the winch (SF22K – SF99K)	30
4.2	Mounting the back roll device (BRD I – IV):	32
4.3	Final mounting:.....	33
4.4	Mounting optional additional components	34
4.4.1	Back roll device with deflection	34
4.4.2	Residual feed flap manual.....	35
4.4.3	Rubber lip	35
4.4.4	Pre-manufactured concrete parts.....	36
4.4.5	End switch on the back roll device	36
4.5	Electrical installation	37
5	Operation	38
5.1	Filling the Feedstar	39
5.2	Emptying Feedstar.....	40
6	Faults.....	41
7	Maintenance and inspection.....	42
7.1	General Information.....	42
7.2	Maintenance plan.....	42
7.3	Overview of lubricating nipple	43
7.4	Repairs.....	43
8	Removal and decommissioning.....	44
8.1	Decommissioning	44
8.2	Final decommissioning	44
9	Recycling and disposal.....	45
10	Conformity declaration.....	46

List of figures

Fig. 1	EMERGENCY STOP button in the area of the winch	20
Fig. 2	EMERGENCY STOP on the external button	20
Fig. 3	Feedstar, schematic overall view	22
Fig. 4	Lateral guide rollers on the pull bar (optional)	23
Fig. 5	Back roll device with deflection pulley (optional).....	23
Fig. 6	Lower back roll device with deflection pulley (optional).....	24
Fig. 7	Back roll device narrow with chain drive (optional)	24
Fig. 8	Steel cover with under beam (optional)	25
Fig. 9	Residual feed flap manual (optional)	26
Fig. 10	End switch back roll device (optional).....	26
Fig. 11	Safety switch back roll device (optional).....	27
Fig. 12	External button	28
Fig. 13	Remote control (optional).....	28
Fig. 14	Control cabinet with main isolation switch.....	29
Fig. 15	Type plate	29
Fig. 16	Mounting winch	30
Fig. 17	Mounting a wire layer	31
Fig. 18	Mounting 1.5 wire layers	31
Fig. 19	Mounting 2 wire layers	31
Fig. 20	Dimensions back roll device	32
Fig. 21	Mounting back roll device.....	32
Fig. 22	Mounting wire and wire stopper	33
Fig. 23	Mounting BRD with deflection.....	34
Fig. 24	Mounting the residual feed flap.....	35
Fig. 25	Mounting rubber lip	35
Fig. 26	Mounting pre-manufactured concrete parts.....	36
Fig. 27	End switch back roll device	36
Fig. 28	Filling the Feedstar	39
Fig. 29	Emptying Feedstar.....	40
Fig. 30	Position of the lubrication nipples	43

1 Notes regarding the documentation

1.1 Purpose

This operating manual should help you to become familiar with the system and to achieve the full functional benefit from its high performance.

The operating manual contains important information for the safe, correct and effective use of the system. The instructions must be complied with carefully, in order to avoid risks, reduce repair costs and downtime, and to increase the reliability and service life of the system.

Persons who are responsible for the installation, commissioning, operation or maintenance of the system must have read, understood and comply with the operating manual. For this reason, it must be kept at the location of the system at all times. The local safety and accident prevention regulations and the chapter "safety" (see Chapter 2) must be complied with.

1.2 Liability

In the case of damage and operating faults which are due to non-compliance with the operating manual, Eder GmbH accepts no liability.

Independent changes and modifications on the system are prohibited for safety reasons. If changes or modifications to the system do not have express approval from Eder GmbH, then the operating permit expires and no liability is accepted for resulting damage

Such changes include, for example:

- Removal of protective equipment
- Changing the belt length/width
- Changing belt speeds

In the case of damage, which is attributable to such interventions, Eder GmbH accepts no liability. The operating permit expires. The risk is borne by the user alone!

We reserve the right to apply the latest technical changes which serve further development and improvement of the system and technical progress.

1.3 Target group

This operating manual is intended for the following target groups:

- trained operating personnel
- trained maintenance personnel

1.4 Display of information

To ensure that you can work with this manual quickly and safely, uniform formatting, numbering, symbols, safety information (see chapter 2.1), terms and abbreviations are used.

▶ Action instructions are indicated by an arrow ▶.

- Lists are identified with bullet points.

NOTE

Here you receive information, in order to avoid possible damage.

INFORMATION

Here you will receive useful information regarding the product in general or for handling.

1.5 Setup and structure of the safety and warning information

The safety information items in this operating manual is structured according to a uniform scheme. They denote residual risks which can cause injuries or damage.

General structure



(Warning symbol)

Type and source of the hazard.

Consequences if not complied with

- ▶ Measures for hazard avoidance

The following applies:

Warning symbol: draws attention to the hazard

Signal word: indicates the severity of the hazard

The safety instructions follow action instructions. The action instructions must be complied with for safety protection.

1.6 Storage of the documents

This operating manual and all the documents applicable must be stored for all persons operating on the system in such a way that they are ready for use at any time. The location of the documents must be identifiable for these persons.

1.7 Validity of the manual

This operating manual is exclusively valid for the Feedstar Vario from Eder GmbH.

2 Safety

When the machine is used, during fault rectification and maintenance, please note the warning signs and symbols which are identified for each action, and all safety signs which are attached to the machine.

2.1 Classification of the action-related warning information

**DANGER**

Indicates a directly hazardous situation which leads to death or serious injuries in the event of non-compliance.

Consequences if not complied with

- ▶ Measures for hazard avoidance

**WARNING**

Indicates a potentially hazardous situation which can lead to death or serious injuries in the event of non-compliance.

Consequences if not complied with

- ▶ Measures for hazard avoidance

**CAUTION**

Indicates a potentially hazardous situation which can lead to minor or light injuries in the event of non-compliance.

Consequences if not complied with

- ▶ Measures for hazard avoidance

2.2 Machine stickers, warning, prohibition and mandatory signs

The information and safety signs attached to the system must be complied with. They must not be changed or removed. Damaged signs must be replaced immediately. The following list serves as an explanation of symbols in this manual or on the machine.

Information and warning signs



Warning of
Hazard location



Warning of dangerous
electrical voltage



Warning of
Entanglement hazard



Warning of
Hand injuries



Warning of
automatic start-up



Warning of
hot surfaces



Warning of falling hazard

Mandatory symbol



isolate before work!



Use eye protection!



Follow the manual!



Wear protective gloves!



Use foot protection!

2.3 General safety information

Knowledge of the basic safety information and safety requirements is the prerequisite for safe use and trouble-free operation of the machine.

This operating manual contains all important information in order to operate the system safely.

The system must be protected against access by unauthorised persons.

The company-internal work protection requirements must be complied with.

NOTE

Operating the system without safety equipment is negligent and does not fall into the area "foreseeable incorrect use"!

This operating manual does therefore not explicitly use warning signs and symbols to identify hazards which can occur with a safety device removed.

Residual risks

Residual risks are risks which, despite a safe design and technical protection equipment, represent an unavoidable, non-obvious risk, which is not apparent from the use of the product.

NOTE

To prevent residual risks, all safety information in this operating manual must be complied with.

During all work, the statutory and occupational trade body requirements regarding occupational safety and accident prevention must be complied with.

Work on the system must only be performed by trained and familiarised specialist personnel.

Independent modifications

Independent modifications can cause hazards to emanate from the Feedstar. Changes, attachments or modifications which can impair the safety must not be made.

2.4 Warning information

2.4.1 Complete system

WARNING

Hazard from manipulation of safety measures and equipment

- ▶ Do not make changes to the system.
- ▶ Modifications on the machine must be approved in writing by the manufacturer.
- ▶ Do not manipulate protective devices.
- ▶ Only operate the machine if all protective devices are properly installed and working.

WARNING



Electrical hazard from indirect contact with parts which have become live due to faulty states

- ▶ Work on the electrical equipment must only be performed by authorised specialist personnel.
- ▶ Only carry out maintenance and retrofitting work on the machine if it is disconnected from the power supply.
- ▶ Switch the machine off at the main switch and secure it against re-switching.
- ▶ Place a sign "Do not switch on machine".
- ▶ Clean electrical equipment regularly and check for damage.
- ▶ Cables must not be clamped or squeezed.
- ▶ Cables must be installed in such a way that they cannot cause tripping hazards or can be damaged.
- ▶ Fix loose connections.
- ▶ Change damaged cables immediately.

WARNING

Hazards from movements of the system components

If the system is switched on during the repair or if the repair is performed with the system running, then it can cause serious or fatal injuries.

- ▶ When working on the system, it is necessary that the system is completely switched off and is secured, for example, against switching back on by means of a lock.
- ▶ Before switching on, make sure that no persons are located within the hazard area.
- ▶ Wear the prescribed personal protective equipment
 - Safety shoes
 - Protective gloves
 - Safety helmet for overhead works

! WARNING

Hazard from automatic start-up

- ▶ Only use the system with functional protective devices.
- ▶ Protection devices must not be removed or manipulated.

! WARNING
Hazard from the missing possibility of switching off the system as quickly as possible in an emergency

- ▶ Location and function of the emergency-stop devices and the procedure in case of emergency must be known to all persons working on the system.
- ▶ The emergency stop devices must always be accessible.
- ▶ In no circumstances must emergency stop devices must be blocked by items, be fixed or used as a hook.
- ▶ After repair work, it must be ensured that all emergency stop devices are functional.

! WARNING
Risk of injury from the structural failure of system components due to corrosion
Mechanical hazard from incorrectly dimensioned or faulty machine parts / static strength
Hazard from breaking components

- ▶ Note the information regarding the intended use for the automatic feeding system.
- ▶ Check the mechanical and electrical components regularly for damage, if necessary, replace damaged parts.
- ▶ Ensure completeness and legibility of all safety and hazard information.
- ▶ Comply with the maintenance intervals.
- ▶ Replace damaged or missing corrosion protection.
- ▶ Wear the prescribed personal protective equipment
 - Safety shoes
 - Protective gloves
 - Safety helmet for overhead works

! WARNING
Hazards from incorrect installation and incorrect or non-approved spare parts

- ▶ If components are replaced, only use original parts or parts approved by the manufacturer.
- ▶ The work must only be performed by trained specialist personnel.

 CAUTION
**Risk of injury from contact with hot surfaces (motor, bearings, drives)**

- ▶ allow motors, bearings and drives to cool before working on the machine.
- ▶ Wear heat-resistant protective gloves.

 CAUTION
Hazards from unsuitable design, placement or identification of operating elements and displays

- ▶ Keep displays and operating parts clean and legible.
- ▶ Replace incorrect labels immediately.
- ▶ Ensure the labelling of the operating parts and warning signs and symbols are in the operator's language.
- ▶ If necessary, label additionally in the operator's language.

 CAUTION
**Hazard from direct contact with, breakdown, arcs, fire or short circuit of live parts, produced by the electrical equipment of the system**

- ▶ Work on the electrical equipment must only be performed by authorised specialist personnel.
- ▶ Work on the system must only be performed in the voltage-free state, in compliance with the safety rules.
- ▶ Only carry out maintenance and retrofitting work on the machine if it is disconnected from the power supply.
- ▶ Switch the machine off at the main switch and secure it against re-switching
- ▶ Place a sign "Do not switch on machine".
- ▶ Clean electrical equipment regularly and check for damage.
- ▶ Cables must not be clamped or squeezed.
- ▶ Cables must be installed in such a way that they cannot cause tripping hazards or can be damaged.
- ▶ Fix loose connections.
- ▶ Change damaged components immediately.
- ▶ Do not operate the machine if damage is present.

 CAUTION
Hazard to health possible in the event of working on system components under severe environmental conditions outside of buildings

- ▶ Wear suitable clothing for the environment.

CAUTION
Hazards from noise in the area of the drives

- ▶ Carry out noise measurements.
- ▶ For values above 80 dBA, wear suitable hearing protection.

2.4.2 Hazards in the area of the Feedstar

WARNING
Hazard from breaking components if the winch or the back roll device do not switch off

- ▶ Only operate the system with functional protective equipment.
- ▶ The function of the switch-off device must be checked before commissioning.

WARNING
Hazard from cutting, rubbing or abrasion**Hazard from rubbing or abrasion on the wire of the winch**

- ▶ Check the wire regularly for damage, if necessary, change.

WARNING
**Hazard from trapping of limbs, entanglement or trapping, being caught in the area of the back roll device**

- ▶ Only carry out work in manual operation and repairs only if the power is disconnected from the system power supply.
- ▶ Only operate the system with functional protective equipment.
- ▶ Use suitable lifting devices for opening the shaft cover.
- ▶ Before switching on, make sure that no persons are located within the hazard area.

WARNING
**Hazard from crushing of limbs in the area of the winch and the optional belt cleaning****Hazard from drawing in, trapping or being caught in the area of the winch**

- ▶ Work on the system must only be performed by trained and familiarised specialist personnel
- ▶ Only operate the system with functional protective equipment.
- ▶ Only carry out work during manual operation of the system.
- ▶ When working on the system, it is especially important that the system is completely switched off and is secured, for example, against switching back on by means of a lock.
- ▶ Before switching on, make sure that no persons are located within the hazard area.

2.4.3 Hazards for people and animals from feed and auxiliary substances

! WARNING**Hazard to health from contact with lubricants and cleaning**

- ▶ Avoid skin contact with lubricating and cleaning agents where possible.
- ▶ After contact with lubricating and cleaning agents, immediately clean skin areas and change contaminated clothing.
- ▶ Do not allow lubricating and cleaning agents to enter the environment.
- ▶ Remove and dispose of leaked substances immediately using a suitable binder.
- ▶ Dispose of lubricating and cleaning agents in accordance with the environmental requirements.

! WARNING**Risk of environmental damage from used substances and materials**

- ▶ Dispose of the substances and materials used (greases, oils, cleaning or solvent materials) in accordance with the statutory provisions.

! WARNING**Risk of injury from slipping, stumbling and falling during weather-related slippery conditions or during cleaning and maintenance work, for example from feed residues**

- ▶ Traffic routes in the internal and external areas of the feed system must always be kept ice- and snow-free.
- ▶ Remove feed residues immediately.
- ▶ Always keep the floor clean and dry in the working area.
- ▶ Connecting cables must be installed in such a way that they cannot cause tripping hazards or can be damaged.

! WARNING**Hazard from handling of feed components**

- ▶ When handling different feeds, pay attention to suitable personal protective equipment.
- ▶ The type of personal protective equipment is dependent on the feed being handled.

! WARNING**Hazard from fire due to dried feed components**

- ▶ Remove feed residues at regular intervals.
- ▶ Keep suitable fire extinguishers ready for use at the system.
- ▶ Do not smoke at the system and no naked flames.

! CAUTION**Hazard from moulds in the feed****Hazard from contamination with toxic plant residues**

- ▶ Clean belt at regular intervals.
- ▶ Dispose of feed residues correctly.
- ▶ Avoid dust turbulence.

! CAUTION**Risk of injury for animals from damaged belt****Risk of injury for animals from damaged wire of the winch**

- ▶ Check the wire of the winch for damage at regular intervals.
- ▶ Repair or replacement damaged belt.

! CAUTION**Hazard from silage wastewater**

- ▶ Dispose of silage wastewater correctly.

2.4.4 Hazards during transport

! CAUTION**Risk of injury during transport, assembly and disassembly from falling system components**

- ▶ Only qualified, trained and inducted personnel must carry out transport.
- ▶ Assign a competent and reliable banksman for lifting processes/loading processes.
- ▶ Use suitable transport vehicles with sufficient load capacity.
- ▶ Use suitable and sufficiently dimensioned lifting devices.
- ▶ Note the requirements for load securing.
- ▶ Note the weight data of the system components.
- ▶ No persons must be present under suspended loads.
- ▶ Take care with the centre of gravity and the inherent weight of the system components.
- ▶ Secure loose components against falling or falling over.

- ▶ Ensure a uniform load distribution.
- ▶ Wear the prescribed personal protective equipment
 - Safety shoes
 - Protective gloves
 - Safety helmet for overhead works

2.5 General protective measures

When working on the Feedstar, care must be taken that no one is endangered. This is particularly true if several persons are present near the system.

Safety devices, protective devices and protection devices must be used and maintained. Abusing them, independent removal and damage is prohibited.

Children must be denied access to the system at all times. In the event of failure to comply, Eder GmbH cannot be held liable.

The measures taken against unauthorised start-up and unauthorised running of the system must not be bypassed.

Making repairs during running operation, as well as cleaning running parts is prohibited.

The Feedstar essentially complies with the following accident prevention requirements.

General requirements	DGUV V1 (former BGV A1 or VBG 1)
Electrical machines	DGUV V3 (former BGV A3 or VBG 4)

2.6 Personal protective equipment

During operation, maintenance, setting up or dealing with faults, personal protective equipment must be used, including for example

- Eye protection
- Hand protection
- Foot protection

2.7 Obligations of the operator

The operator of the system must ensure that

- the commissioning and operation of the machine is performed exclusively by trained personnel.
- the cleaning is performed by trained specialist personnel.
- this operating manual is always available. It is part of the product.
- the operating manual and in particular the safety information have been read and understood by the personnel tasked with work before operation, maintenance and repair.
- the permissible operating conditions are complied with.
- in the case of replacement only original parts, parts approved by the manufacturer or parts with corresponding specifications are used. Other parts must only be installed following agreement with the manufacturer.
- the machine is only operated in the fault-free, operation-safe state. The technical condition must meet country-specific statutory requirements and regulations at all times.
- the system is only used according to the intended use.
- all safety provisions are complied with.
- all maintenance tasks are performed on time and properly.
- all maintenance tasks are performed exclusively by trained personnel.
- all maintenance work is performed exclusively by corresponding specialist personnel.

2.8 Training of the personnel

Before commissioning, the personnel must be fully trained regarding:

- the operation of the system
- the execution of proper maintenance

The operator must ensure that the training is repeated at reasonable intervals.

2.9 Protection devices / EMERGENCY STOP button

Protective devices are used to protect you against injuries in hazard areas.

- ▶ Only use the system with intact and functional safety devices. Before switching on, check whether all safety devices are installed.

Two EMERGENCY STOP buttons are provided on the Feedstar at the following areas:

- On the control unit
- In the area of the winch (installation by customer)

In the case of emergency, the EMERGENCY STOP button interrupts the power supply and stops the system.

- ▶ Always keep access to the EMERGENCY STOP buttons free. Do not manipulate them. Do not use for an unsuitable use, for example as a clothes hook.



Fig. 1 EMERGENCY STOP button in the area of the winch



Fig. 2 EMERGENCY STOP on the external button

3 Functional description

3.1 Use as intended

The Feedstar must be used exclusively for horizontal transport of green feed or mixing ration on smooth floors.

Intended use also includes compliance with the operating, maintenance and repair conditions specified by the manufacturer.

The system must only be used by persons who are familiar with it and are informed about the risks associated with it.

3.2 Foreseeable incorrect use

Any other use than the use described above can cause risks and damage and is not intended use. In particular this includes:

- use as a lifting device
- the overloading of the system
- Operation, maintenance and service by persons who are not trained
- the improper use with unsuitable parameters and operation in unsuitable environmental conditions (see Chapter. 3.8 Technical data)
- the transport of people and animals
- the use of the system in damaged condition
- the non-compliance with the operating manual
- the non-compliance with the relevant accident prevention regulations
- the use of non-approved equipment and operating media
- an inadequate or improper maintenance and servicing
- the execution of non-approved changes
- the use of unsuitable replacement and wear parts
- operation without safety devices
- the manipulation of protective devices

The manufacturer is not liable for this damage; the risk for this is solely borne by the user.

3.3 Retrofitted components

In the case of components installed retrospectively, unless they are supplied by Eder GmbH and/or installed, the operating permit will expire.

With components and retrofits supplied by Eder GmbH the operator must carry out a corresponding assessment of the risks.

Independent changes to the machine exclude liability of the manufacturer for resulting damage.

3.4 Design of the Feedstar Vario

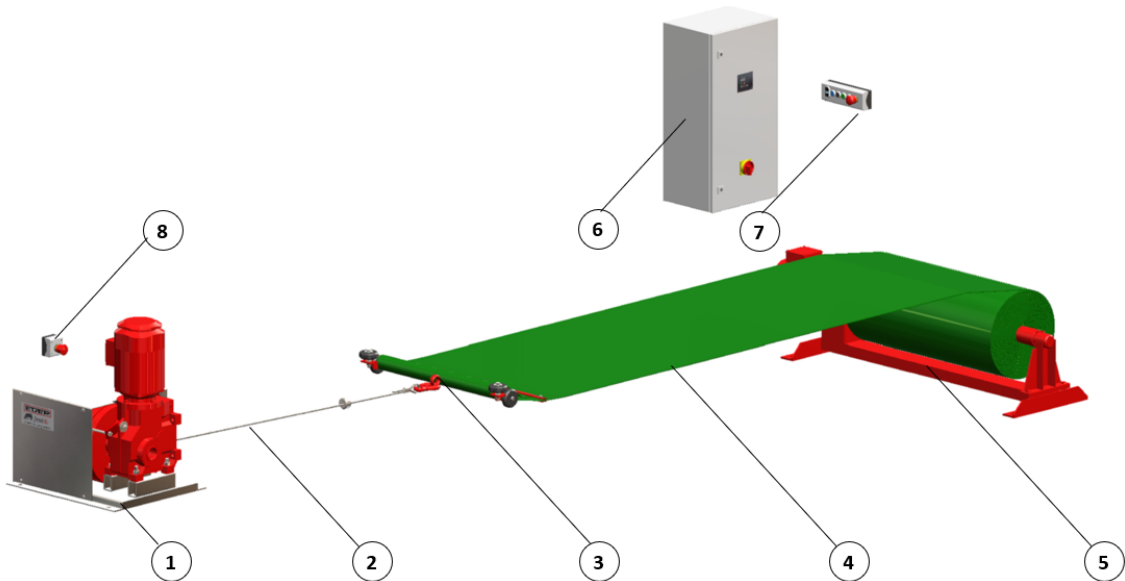

Fig. 3 Feedstar, schematic overall view

Pos.	Description	Pos.	Description
1	Winch with motor	5	Back roll device
2	Wire	6	Control cabinet with main switch
3	Pull bar	7	External button
4	Feed belt	8	Emergency stop

3.5 Optional additional components

3.5.1 Lateral guide rollers on the pull bar

Additional guide rollers on the pull bar for extra long or wide systems. In the area of the winch, these hold the pull bar in the U-shell. The rollers must never be adjusted too tight:

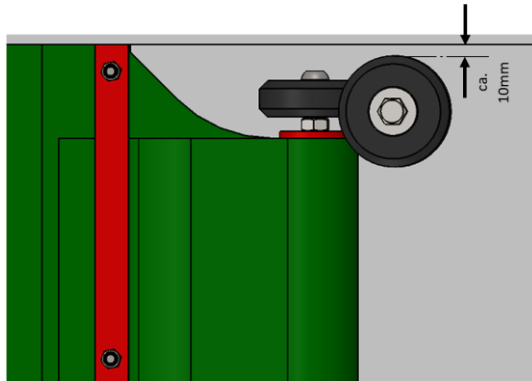

Fig. 4 Lateral guide rollers on the pull bar (optional)

3.5.2 Back roll device with deflection pulley

The back roll device can optionally be equipped with a deflection pulley. This allows the feed to be ejected behind the back roll device.

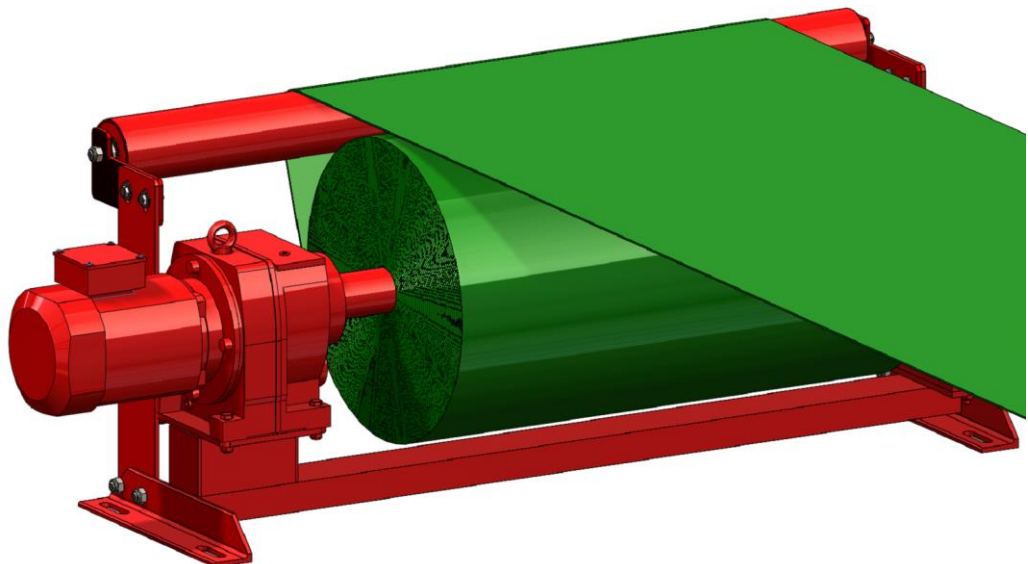

Fig. 5 Back roll device with deflection pulley (optional)

3.5.3 Lower back roll device with deflection pulley

Due to the cross bar being divided, the back roll device is lower than the standard. This means that the back roll device is approximately 5-12mm lower than a standard back roll device.

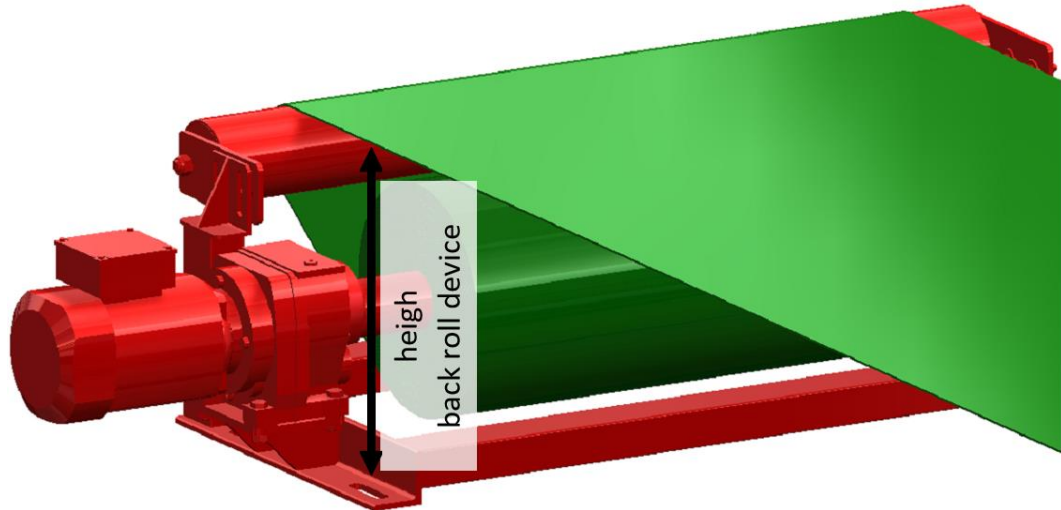

Fig. 6 Lower back roll device with deflection pulley (optional)

3.5.4 Back roll device narrow with chain drive

Here the motor is displaced forwards by means of a chain drive in order to be able to save space laterally.

Space requirements motor side instead of 750mm - approx. 300mm

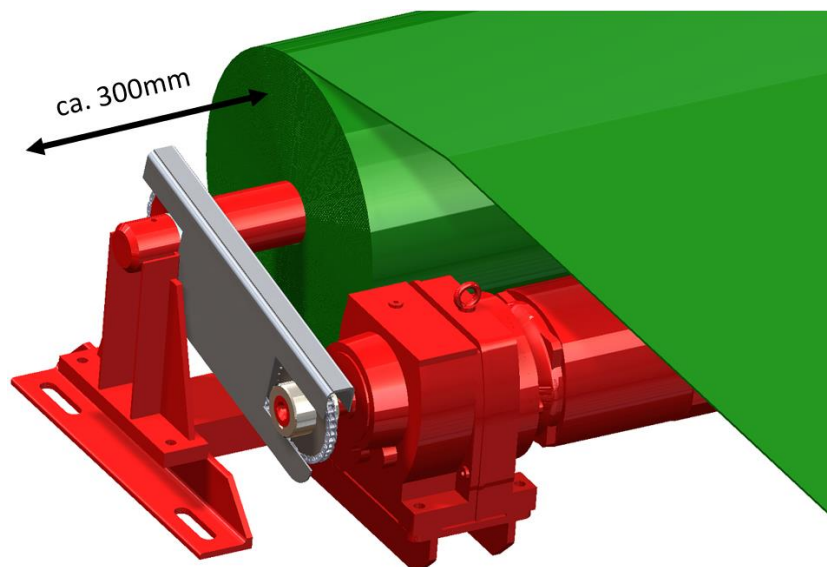

Fig. 7 Back roll device narrow with chain drive (optional)

3.5.5 Steel cover with under beam

Steel cover for covering the shaft of the back roll device.

Maximum load approx. 5 t. Size variable. Measurements see assembly drawing.

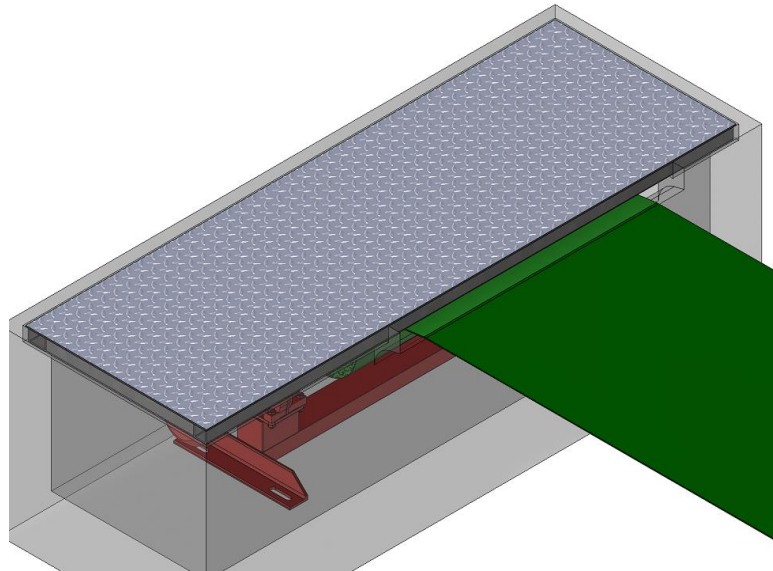

Fig. 8 Steel cover with under beam (optional)

3.5.6 Residual feed flap manual

The residual feed flap allows lateral pushing of the residual feed.

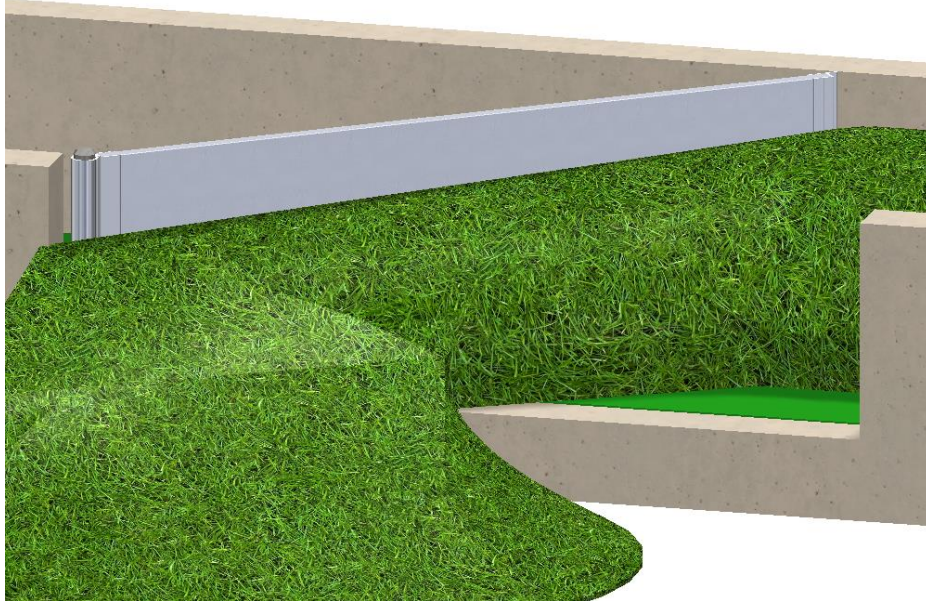

Fig. 9 Residual feed flap manual (optional)

3.5.7 End switch for back roll device

The back roll device can optionally be equipped with an end switch. This automatically stops the system as soon as the belt is pulled out.

This end switch requires an additional automatic system and is not for the standard control.

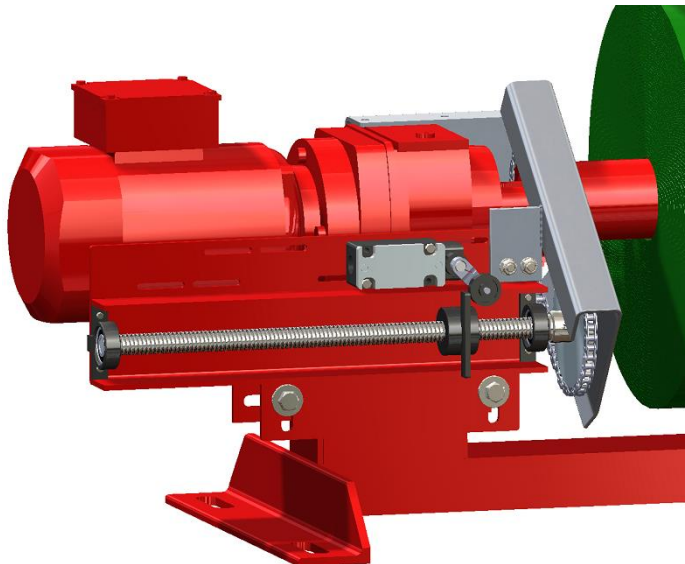

Fig. 10 End switch back roll device (optional)

3.5.8 Safety switch for end switch of the back roll device

In addition to the end switch, the back roll device can be equipped with a safety switch. This stops the back roll device if the belt is moved to the side or folded over during rolling in. The safety switch is only designed in conjunction with the end switch and is intended for wide or long systems.

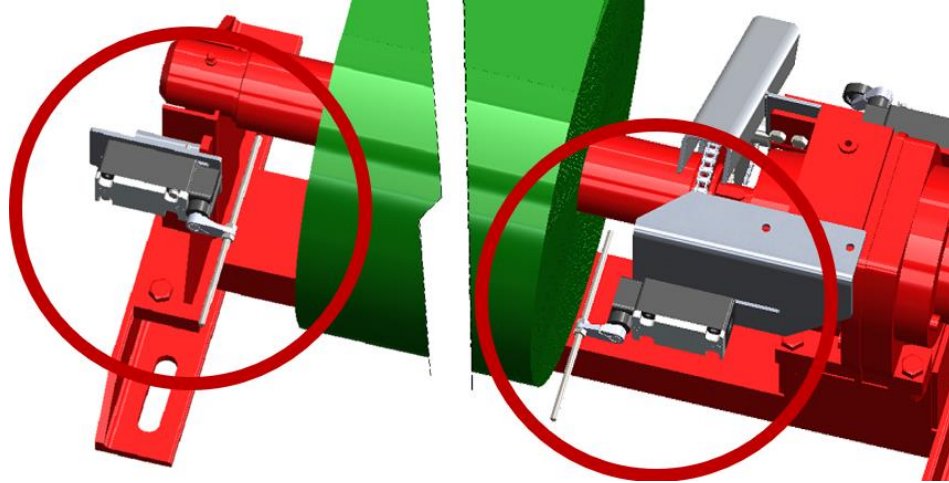

Fig. 11 Safety switch back roll device (optional)

3.6 Control unit

The system is controlled via a mobile control unit.

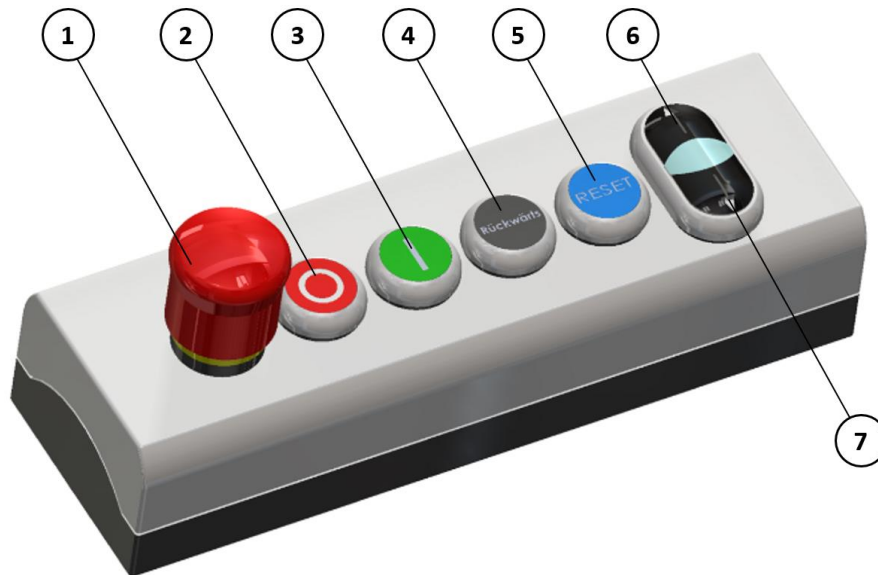

Fig. 12 External button

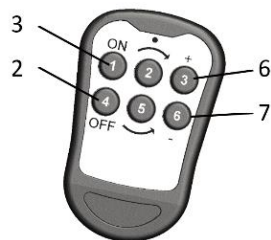

Fig. 13 Remote control (optional)

Pos.	Description and function
1	EMERGENCY STOP button
2	Pressing the button switches the belt off
3	Pressing the button switches the belt on. The belt runs into the shed (forward).
4	Pressing the button (keep pressed!) the belt will run out of the shed (backward)
5	Pressing the button resets the system after a fault or EMERGENCY STOP
6	Pressing the button increases the belt speed
7	Pressing the button reduces the belt speed

3.7 Control cabinet

The main isolation switch is located on the control cabinet.



Fig. 14 Control cabinet with main isolation switch

3.8 Type plate



Fig. 15 Type plate

3.9 Technical data

Winch type	SF22K	SF33K	SF44K	SF88K	SF99K
Loading with material max. [t]	1.8	3	4	6.5	8
Usable wires (stainless), Diameter [mm]	8	8	8	10	12
flexible belt speed [m/min]	5.5-12.5	6-13	6-13	8-18	8.5-20
Motor power for flexible belt speed [kW]	1.5	3	4	8.3	11-16

All data are guideline values and must be determined individually.

4 Mounting

During the mounting of the system, the safety information in Chapter 2.3 and warning signs and symbols referred to in Chapter 2.4 must be complied with – this avoids potentially fatal injuries, machine damage and other property damage.

4.1 Mounting of the winch (SF22K – SF99K)

The winch is mounted horizontally at the end of the belt at the level of the feed table. The winch is fixed with 4-6 bolt anchors (depending on the size of the winch).

- ▶ Once the wire is fully wound onto the winch, the hook must be located to the side of the feed table centre (3-8 cm). The feed table centre is marked on the winch. Only this allows an optimal drawing in of the belt.
- ▶ The length of the wire must be selected in such a way that, with a fully rolled feed belt at least 3 wire layers are still present on the drum winch.
- ▶ In every layer, the wire must be wound up cleanly row by row; as pre-mounted.

To achieve this, the winch must be tilted slightly if necessary, according to the wire length or number of the rope layers:

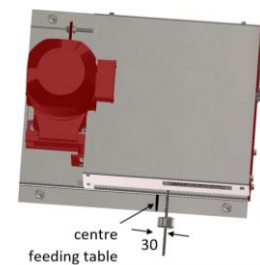
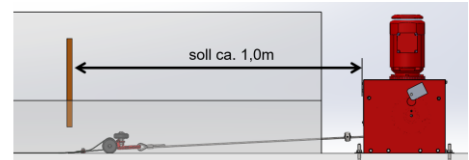
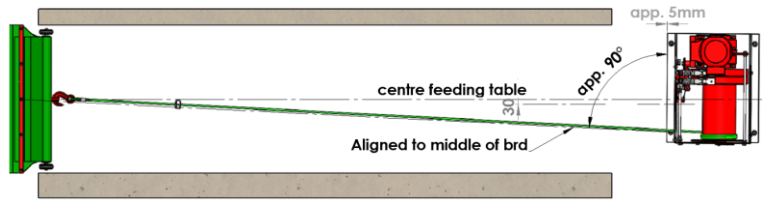

Fig. 16 Mounting winch

Tilted winch for 1 wire layer

Belt not drawn in



Belt drawn in

Winch inclined approx. 5mm

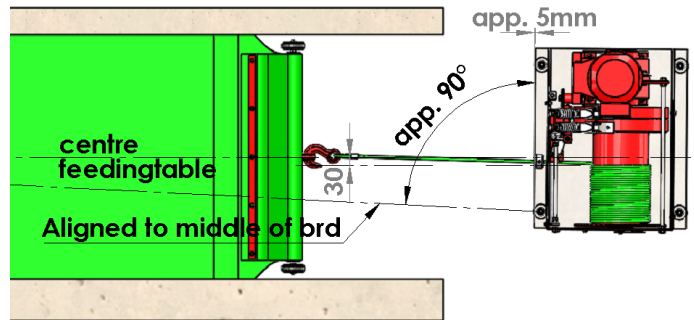

Fig. 17 Mounting a wire layer

Straight winch with 1.5 wire layers

Winch 90° with the feed table

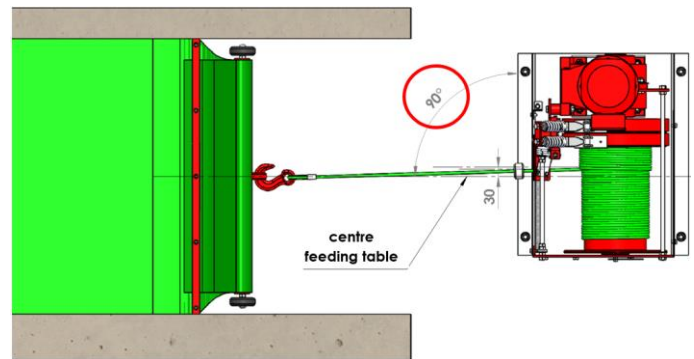

Fig. 18 Mounting 1.5 wire layers

Tilted winch for 2 wire layers

Winch 5mm inclined to the feed table

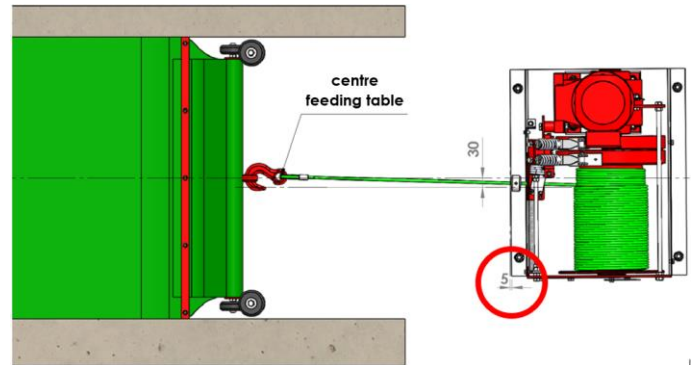

Fig. 19 Mounting 2 wire layers

WARNING



Risk of trapping in the area of the winch

- ▶ The supplied protective hood must be mounted.
- ▶ The system must not be operated without a protective hood.

4.2 Mounting the back roll device (BRD I – IV):

- ▶ The back roll device is mounted horizontally and angularly aligned with the belt.
- ▶ The back roll device is mounted anchored in the floor as standard. The dimensions of the recess are determined by the width and length of the feed belt. For this see the enclosed assembly drawing with the project-specific dimensions.
- ▶ The back roll device is fixed in the shaft with 4 bolt anchors and large washers.

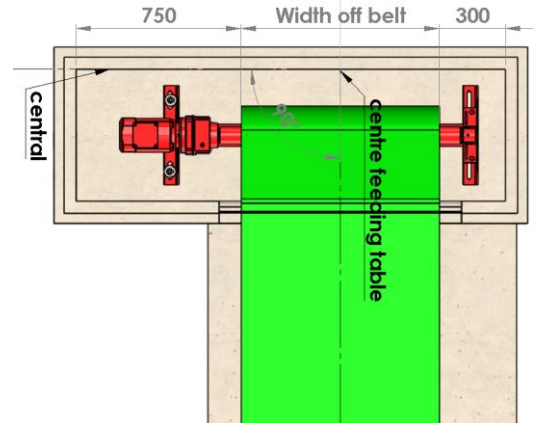

Fig. 20 Dimensions back roll device

- ▶ Pull the belt into the U-shell approximately 3-4m and set the back roll device exactly at 90° to the feed table. At the suspended transition (on one side the belt is tight on the other it hangs down) you will see if it is correctly aligned. The angular mounting can be readjusted using the elongated holes on the back roll device.

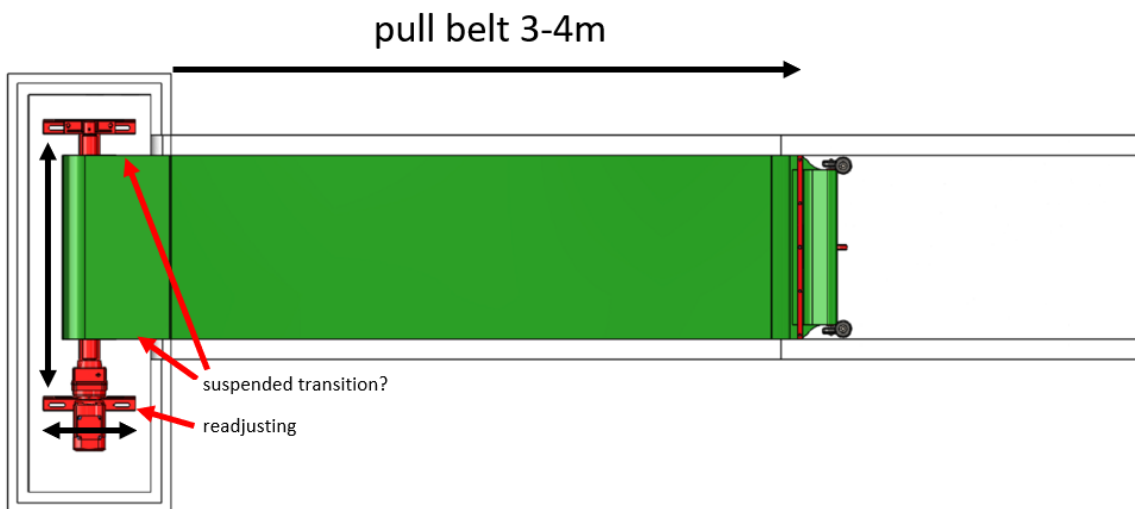
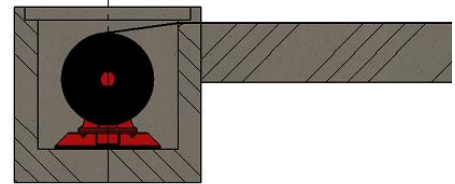
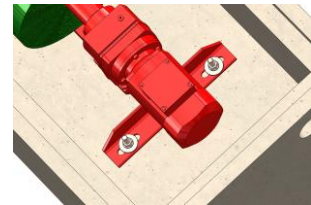

Fig. 21 Mounting back roll device

⚠ WARNING
Risk of tripping and entanglement in the area of the back roll device

The recessed back roll device must be secured with a non-slip plate suitable for walking on.

The system must not be operated without this plate.

4.3 Final mounting:

- ▶ Pull out the wire and hook into the pull bar.

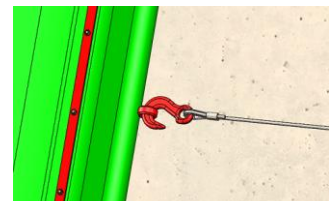

- ▶ The setting of the end position on the winch can be adjusted by sliding the wire stopper.

Please take the exact mounting dimensions and the electrical installation from the assembly drawing.

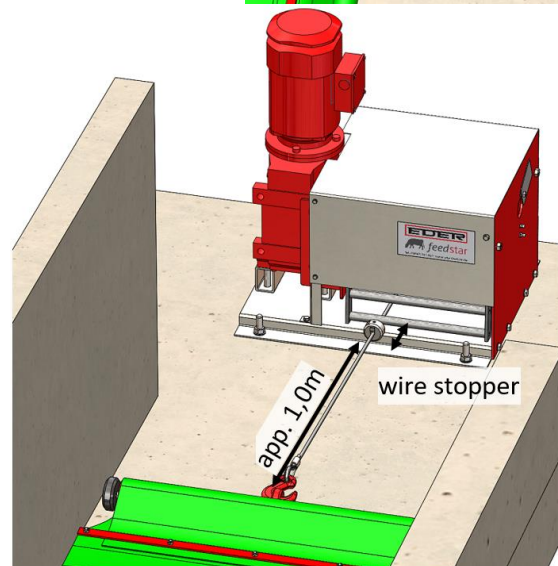
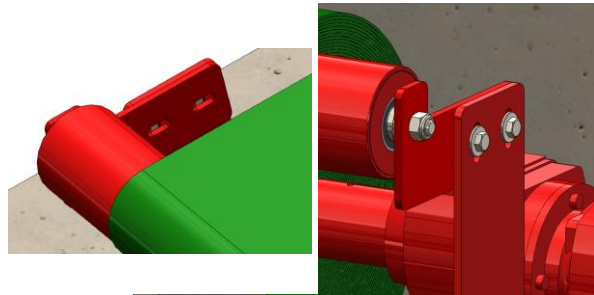
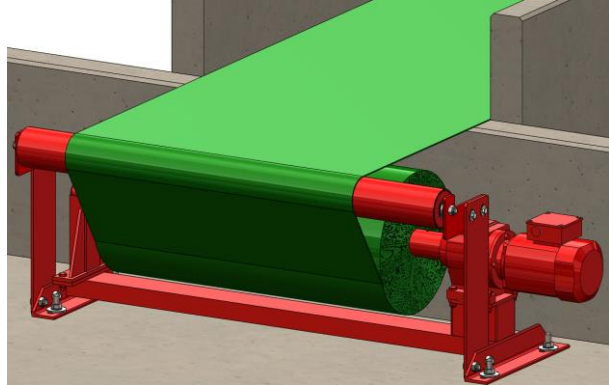

Fig. 22 Mounting wire and wire stopper

4.4 Mounting optional additional components

4.4.1 Back roll device with deflection

- ▶ The back roll device is fixed to the floor with 4 bolt anchors and large washers.
- ▶ The angle of the back roll device can be adjusted correctly using the elongated holes.
- ▶ The deflection pulley is also set up exactly at the correct height and level using elongated holes.



The belt roller, deflection and feed table must be as exactly parallel to one another or perpendicular as possible

An example showing how the deflection pulley can be enclosed by the customer

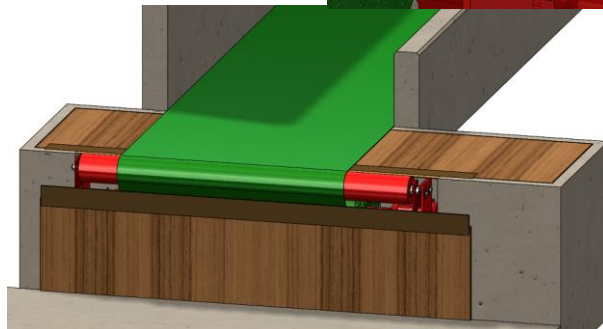

Fig. 23 Mounting BRD with deflection

4.4.2 Residual feed flap manual

The residual feed flap is composed of a vertical pipe and an aluminium flap.

The height of the plate is 400mm, the length varies according to the belt width.

- ▶ The vertical pipe is mounted flush with the inner edge with 2 bolt anchors in such a way that the distance of the flap to the fold is approximately 5-7mm. The flap is only placed on.

Image example for BRD right (left mirror image)

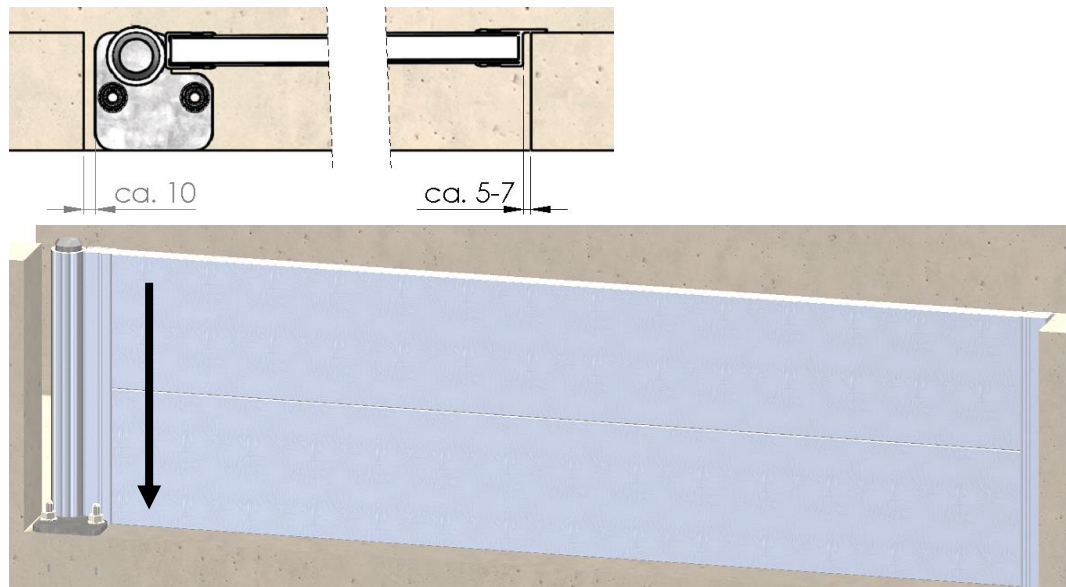

Fig. 24 Mounting the residual feed flap

4.4.3 Rubber lip

The rubber lip has the following dimensions: 200cm x 8.0cm x 0.8cm.

No fastening material is supplied, because the rubber can be attached in a wide variety of locations. For this the lip must also be cut to shape. Here a few examples:

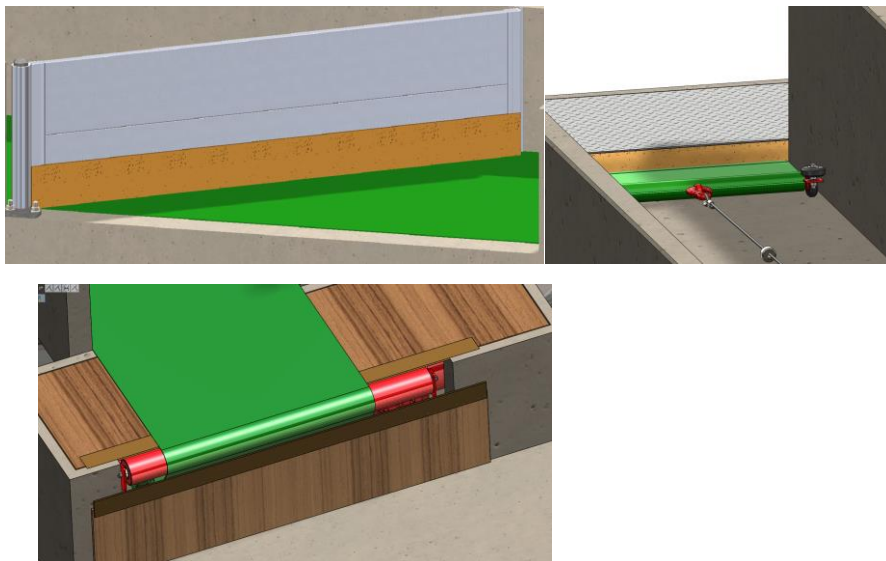

Fig. 25 Mounting rubber lip

4.4.4 Pre-manufactured concrete parts

The supplied concrete parts must be installed in accordance with the specifications of the German concrete manufacturers association and the currently applicable accident prevention regulations. Maximum permissible dimensional deviations in accordance with Table 1 of DIN 18202.)

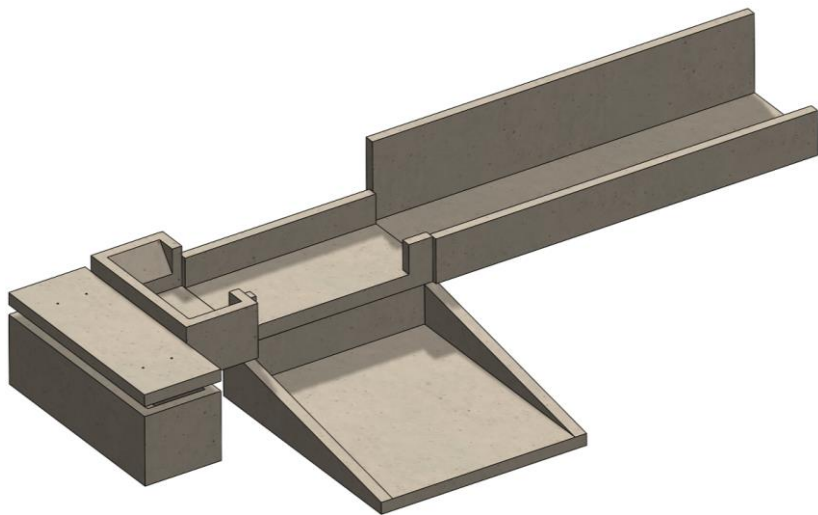

Fig. 26 Mounting pre-manufactured concrete parts

4.4.5 End switch on the back roll device

Place the belt at the position of the end stop, move the chain and end switch in such a way that the black metal actuates the end switch if the belt moves back to the stop point.

The tolerance is approximately 50cm.

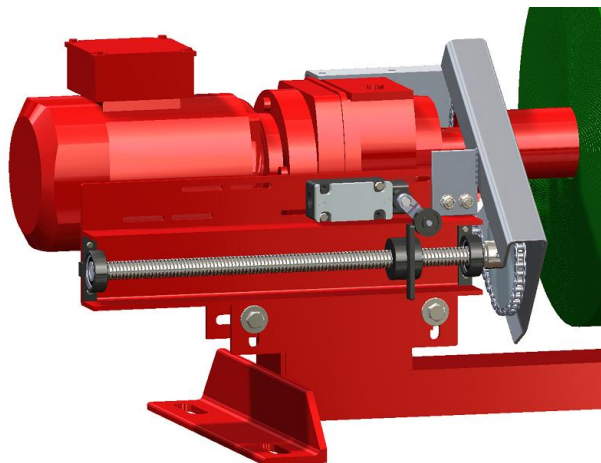

Fig. 27 End switch back roll device

4.5 Electrical installation

- ▶ The electrical connection must only be carried out by a specialist, for example, make sure that the winch runs in the correct direction! The contactors, as well as on and off switches are supplied with the E-mounting plans.
- ▶ If a frequency converter is used for continuous speed, it must be mounted a maximum of 50 m from the winch in order to ensure proper operation. The use of a shielded cable is mandatory.
- ▶ A sensitive circuit-breaker (RCD type B, specified according to power on site) must be connected upstream of the frequency converter.
- ▶ The functions of the switch-off device (end switch) must be checked before commissioning! The check must be performed during loading and low speed in order to prevent the transmission running on.
- ▶ During the mounting of the control cabinet, keep the statutory accident prevention regulations on a wall.
- ▶ When the control cabinet is mounted on a wall, be aware of the load-bearing capacity of the wall. If the load-bearing capacity of the wall is not sufficient: Use a different, statically strong and secure construction.
- ▶ Place the cable in such a way that no tripping points are created.
- ▶ Damaged cables (breaks, cracks) must be replaced immediately in order to prevent injuries.

The system is therefore ready for operation.

NOTE

Upon pressing the reverse button (see Fig. 12 or Fig. 13 Pos. 3) the wire winch initially runs backwards for approximately 3 seconds before the back roll device is switched on.

5 Operation

During the operation of the system, the safety information in Chapter 2.3 and warning signs and symbols referred to in Chapter 2.4 must be complied with – this avoids potentially fatal injuries, machine damage and other property damage.

- ▶ Before starting work, familiarise yourself with the system. During the work it is too late!
- ▶ Check whether the wire, feed belt and electrical components (especially end switch off and deadman circuit) are in proper condition before each operation. The check must be performed during loading and low speed in order to prevent the transmission running on.
- ▶ If the wire drum is running on, check the brake linings for oil contamination. Clean or renew the linings if necessary.
- ▶ Check the protective devices for functional performance before each operation.
- ▶ If you notice safety relevant changes, do not place the system in operation! First place all the protective devices in a proper condition.
- ▶ Make sure that no obstacles can enter the tension belt and the tensile force increases until a wire breaks.
- ▶ Switch the system on at the main switch (see Fig. 14).
- ▶ From a filling quantity of approximately 60% the belt must be run through to the end stop because it's possible that the winch is unable to start due to overloading.

The system is now in operation.

NOTE

Upon pressing the reverse button (see Fig. 12 or Fig. 13 Pos. 3) the wire winch initially runs backwards for approximately 3 seconds before the back roll device is switched on.

5.1 Filling the Feedstar

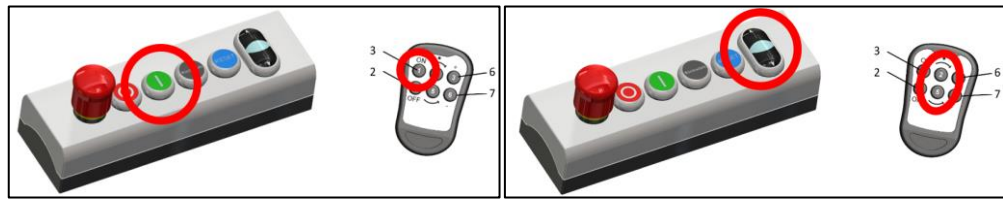

Start the belt

Change speed

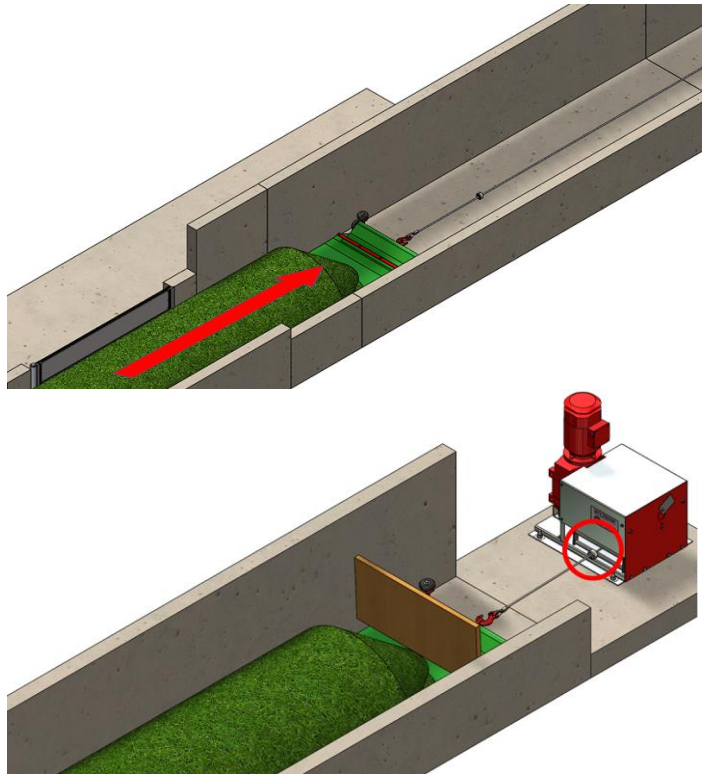

Fig. 28 Filling the Feedstar

- ▶ Let the feed belt run into the shed (see 3.6 control unit).
- ▶ Slowly tip feed from a storage vessel or filling device onto the belt.
- ▶ The belt starts running at the slowest speed.
- ▶ The filling height can be changed by regulating the belt speed with the buttons 6 + 7 (see Fig. 12 and Fig. 13).
- ▶ The belt must be filled evenly and allow it to run through continuously until the end switch from 2/3 full. Avoid stopping and restarting with filled belt.
 - The system has an end switch. Once the belt has fully entered into the shed, the system automatically stops.
 - A final board (provided by customer) prevents contamination of the area between the winch and belt. To ensure that the pull bar passes under it, we recommend a distance of approximately 10 -12cm without guide rollers and 13 – 15cm for a pull bar with guide rollers.
- ▶ Then end the filling process.

5.2 Emptying Feedstar



Belt reverse

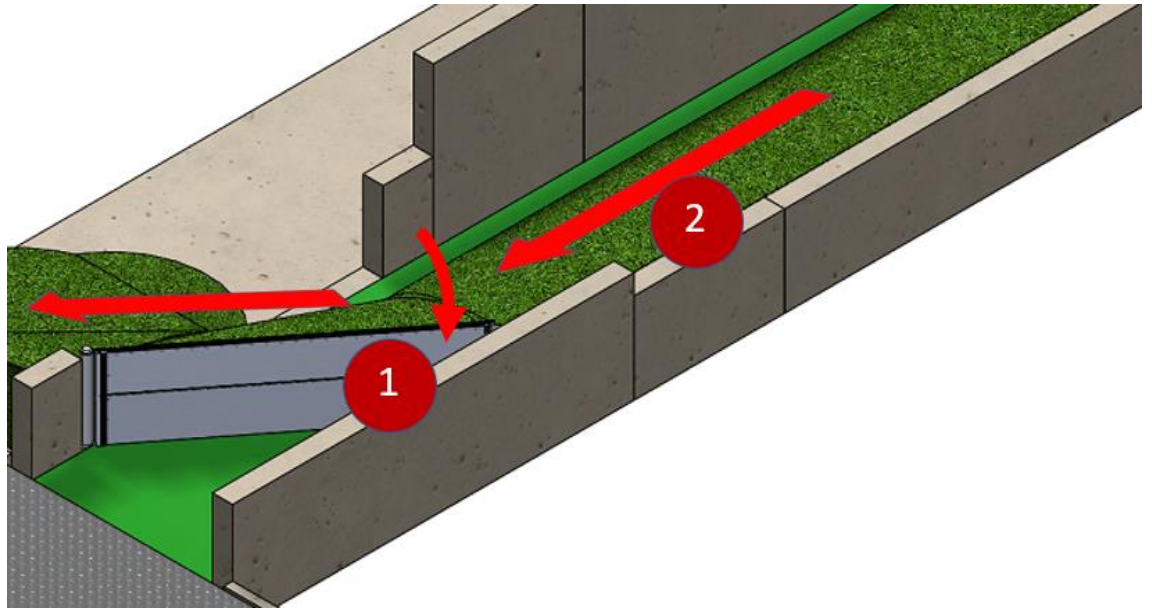

Fig. 29 Emptying Feedstar

- ▶ (1) Open the residual feed flap (optional, see Fig. 9) in order to collect the remaining feed in the floor trough.
- ▶ (2) Let the feed belt run out of the shed.
- ▶ If the back roll device is equipped with an end switch (optional, see Fig. 10), the system automatically stops once the belt has run out of the barn.
- ▶ Close the residual feed flap.

The system is ready for the next filling.

6 Faults

During the rectification of faults, the safety information in Chapter 2.3 and warning signs and symbols referred to in Chapter 2.4 must be complied with – this avoids potentially fatal injuries, machine damage and other property damage.

Fault	Cause	Rectification
Feed belt judders during running into the shed	There is an obstacle in the track	Remove the obstacle.
Belt does not move	The main switch in position "O"	Switch the system on.
	Emergency stop pressed	Check the emergency-stop switch
	There is an obstacle in the track.	Remove the obstacle.
	The wire is not connected to the pull bar or is torn	Connect the wire to the pull bar if it is still long enough. Otherwise replace the wire.
	The batteries of the remote control are too weak	Change the batteries of the remote control.
Drive makes unusual noises	Motor or cables are defective	Switch the system off and call the Service-Hotline of Eder GmbH.
	Motor or chain drive are defective	Switch the system off and call the Service-Hotline of Eder GmbH.
Winch runs on	Belt not loaded	Belt loaded
	Brake linings oiled or worn out	Degrease brake linings, retention spring or

7 Maintenance and inspection

7.1 General Information

During the maintenance and inspection of the system, the safety information in Chapter 2.3 and warning signs and symbols referred to in Chapter 2.4 must be complied with – this avoids potentially fatal injuries, machine damage and other property damage.

Cleaning and maintenance work must only be performed by authorised personnel - the operating instructions must be complied with exactly.

Replacement parts must meet at least the technical requirements specified by the device manufacturer.

Only carry out maintenance, cleaning and repair work with stationary drives and main switch switched off.

All work on the electrical equipment of the machine must only be performed by trained electrical specialists.

NOTE

After the end of maintenance or repair, make sure that no tools, cleaning articles or other parts are present in the system.

NOTE

In your own interest, please note that necessary repairs or maintenance which extend beyond this technical documentation during the warranty period can only be carried out by Eder GmbH themselves.

7.2 Maintenance plan

Activity	weekly	quarterly	if required
Check the wire and feed belt for wear (especially pay attention to the rubber lip at the table inlet)	X		
Clean the system		X	
Lubrication of the drives Winch: three lubricating nipples on the side of the winch and the two lubricating nipples on the inner side of the drum Back roll device: all existing lubrication nipples (see chap. 7.3)		X	
If the wire drum is running on: Check the brake linings for oil contamination. Clean or renew the linings			X
If end switch is present on the back roll device: Lubricate spindle			X six monthly

7.3 Overview of lubricating nipple

Lubrication nipple winch outer side (3 x)	
Lubricating nipple winch inner side (2 x)	
Lubrication nipple back roll device	

Fig. 30 Position of the lubrication nipples

7.4 Repairs

NOTE

Required repairs must only be performed by authorised and appropriately trained specialist personnel. The accident prevention regulations must be complied with.

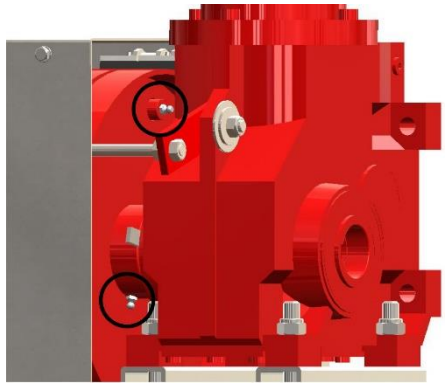
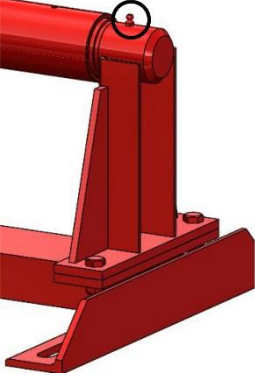
8 Removal and decommissioning

During the removal and decommissioning of the system, the safety information in Chapter 2.3 and warning signs and symbols referred to in Chapter 2.4 must be complied with – this avoids potentially fatal injuries, machine damage and other property damage.

The decommissioning of the system must only be performed by qualified persons in accordance with the safety information.

8.1 Decommissioning

For temporary decommissioning, the system must be switched off at the main switch.

8.2 Final decommissioning

For the final decommissioning in addition to the points mentioned above the securing of the main switch against re-switching must also be ensured.

9 Recycling and disposal

The system consists largely of valuable recyclable materials which are to be sent for recycling. Using a modular design, dismantling into its component parts is possible without problems.

Make sure that all applicable laws, standards, regulations and regional regulations are complied with during the disposal of the system.

Take the system completely out of operation.

Separate the dismantled parts according to material.

Make sure that the parts to be disposed of and if necessary, the existing accessories are sent for proper disposal.

Once the system reaches the end of its life cycle, it must be ensured that safe and proper disposal, in particular of parts or substances which are harmful to the environment, take place during its dismantling.

INFORMATION

We recommend you to engage a certified regional specialist company to dispose of your machine.

10 Conformity declaration

EG-Konformitätserklärung

im Sinne der EG-Maschinenrichtlinie 2006/42/EG, Anh. II 1. A

Hersteller	In der Gemeinschaft ansässige Person, die bevollmächtigt ist, die technischen Unterlagen zusammenzustellen
EDER GmbH	Geschäftsführer
Moorweg 5	EDER GmbH
DE - 83104 Tuntenhausen	Moorweg 5 DE - 83104 Tuntenhausen

Beschreibung und Identifizierung der Maschine

Produkt / Erzeugnis	Futterband
Type	
Seriennummer	
Handelsbezeichnung	Futterband
Funktion	Aus einem Vorratsbehälter wird Grünfutter oder Mischration auf ein Futterband gekippt. Durch eine Seilwinde wird das beladene Futterband gleichmäßig in einem Futtertrog über die gesamte Länge der Fütterungszone gezogen. Die Abschaltung der Seilwinde erfolgt über einen Endschalter an der Seilwinde. Nach Beendigung der Fresszeit wird das Futterband von einem Bandrückführsystem aufgewickelt. Evtl. vorhandenes Restfutter wird von einem beweglichen Abstreifer (Gurtreinigung) in eine Auffanggrube neben dem Futterband befördert.

Es wird ausdrücklich erklärt, dass die Maschine allen einschlägigen Bestimmungen der folgenden EG-Richtlinien bzw. Verordnungen entspricht:

2006/42/EG	Richtlinie 2006/42/EG des Europäischen Parlaments und des Rates vom 17. Mai 2006 über Maschinen und zur Änderung der Richtlinie 95/16/EG (Neufassung) (1) Veröffentlicht in L 157/24 vom 09.06.2006
2014/30/EU	Richtlinie 2014/30/EU des Europäischen Parlaments und des Rates vom 26. Februar 2014 zur Harmonisierung der Rechtsvorschriften der Mitgliedstaaten über die elektromagnetische Verträglichkeit (Neufassung) Veröffentlicht in L 96/79 vom 29.03.2014

Fundstelle der angewandten harmonisierten Normen entsprechend Artikel 7 Absatz 2:

EN ISO 12100:2010-11	Sicherheit von Maschinen - Allgemeine Gestaltungsleitsätze - Risikobewertung und Risikominderung (ISO 12100:2010)
EN ISO 13857:2008	Sicherheit von Maschinen - Sicherheitsabstände gegen das Erreichen von Gefährdungsbereichen mit den oberen und unteren Gliedmaßen (ISO 13857:2008)
EN 14492-1:2006+A1:2009/AC:2010	Krane - Kraftgetriebene Winden und Hubwerke - Teil 1: Kraftgetriebene Winden
EN 60204-1:2006/AC:2010	Sicherheit von Maschinen - Elektrische Ausrüstung von Maschinen - Teil 1: Allgemeine Anforderungen
EN 620:2002+A1:2010	Stetigförderer und Systeme - Sicherheits- und EMV-Anforderungen für ortsfeste Gurtförderer für Schüttgut
EN 1037:1995+A1:2008	Sicherheit von Maschinen - Vermeidung von unerwartetem Anlauf
EN ISO 14120:2015	Sicherheit von Maschinen — Trennende Schutzeinrichtungen — Allgemeine Anforderungen an Gestaltung, Bau und Auswahl von feststehenden und beweglichen trennenden Schutzeinrichtungen (ISO 14120:2015)
EN ISO 13849-1:2015	Sicherheit von Maschinen — Sicherheitsbezogene Teile von Steuerungen — Teil 1: Allgemeine Gestaltungsleitsätze (ISO 13849-1:2015)
EN ISO 13850:2015	Sicherheit von Maschinen — Not-Halt — Gestaltungsleitsätze (ISO 13850:2015)
EN 60204-1:2006/A1:2009	Sicherheit von Maschinen - Elektrische Ausrüstung von Maschinen - Teil 1: Allgemeine Anforderungen

Tuntenhausen,

Ort, Datum

Unterschrift
Georg Pfeilschiffer
Geschäftsführer